

SOCKET WELD TUBE ELBOW FLANGES (Pg 1/2)

SAE BOLT PATTERN										61 SERIES					
FLANGE SIZE	TUBE SIZE	PART NUMBER	A	B	C	D	E	F	G J	H	K	MOUNTING KIT®			WT
												PART NO.	SCREW SIZE	O-RING	
1/2	3/8	1129-08-06	1.75	2.12	1.44	1.500	.688	.50	.34	.75	.385	MK 541	5/16-18 x 2	210	1.3
		1130-08-06							5/16-18						
1/2	1/2	1129-08-08	1.75	2.12	1.44	1.500	.688	.50	.34	.75	.510	MK 541	5/16-18 x 2	210	1.3
		1130-08-08							5/16-18						
1/2	5/8	1129-08-10	1.75	2.12	1.44	1.500	.688	.50	.34	.75	.635	MK 541	5/16-18 x 2	210	1.2
		1130-08-10							5/16-18						
1/2	3/4	1129-08-12	1.75	2.12	1.44	1.500	.688	.50	.34	.75	.760	MK 541	5/16-18 x 2	210	1.2
		1130-08-12							5/16-18						
3/4	1/2	1129-12-08	2.00	2.62	1.70	1.875	.875	.75	.41	.88	.510	MK 542	3/8-16 x 2 1/2	214	2.1
		1130-12-08							3/8-16						
3/4	3/4	1129-12-12	2.00	2.62	1.70	1.875	.875	.75	.41	.88	.760	MK 542	3/8-16 x 2 1/2	214	2.0
		1130-12-12							3/8-16						
3/4	7/8	1129-12-14	2.00	2.62	1.70	1.875	.875	.75	.41	.88	.885	MK 542	3/8-16 x 2 1/2	214	2.0
		1130-12-14							3/8-16						
3/4	1	1129-12-16	2.00	2.62	1.70	1.875	.875	.75	.41	.88	1.010	MK 542	3/8-16 x 2 1/2	214	1.9
		1130-12-16							3/8-16						
1	3/4	1129-16-12	2.25	2.82	1.94	2.062	1.031	1.00	.41	1.00	.760	MK 543	3/8-16 x 2 3/4	219	2.8
		1130-16-12							3/8-16						
1	1	1129-16-16	2.25	2.82	1.94	2.062	1.031	1.00	.41	1.00	1.010	MK 543	3/8-16 x 2 3/4	219	2.7
		1130-16-16							3/8-16						
1	1 1/4	1129-16-20	2.25	2.82	1.94	2.062	1.031	1.00	.41	1.00	1.260	MK 543	3/8-16 x 2 3/4	219	2.6
		1130-16-20							3/8-16						

MATERIAL:
Low Carbon Steel

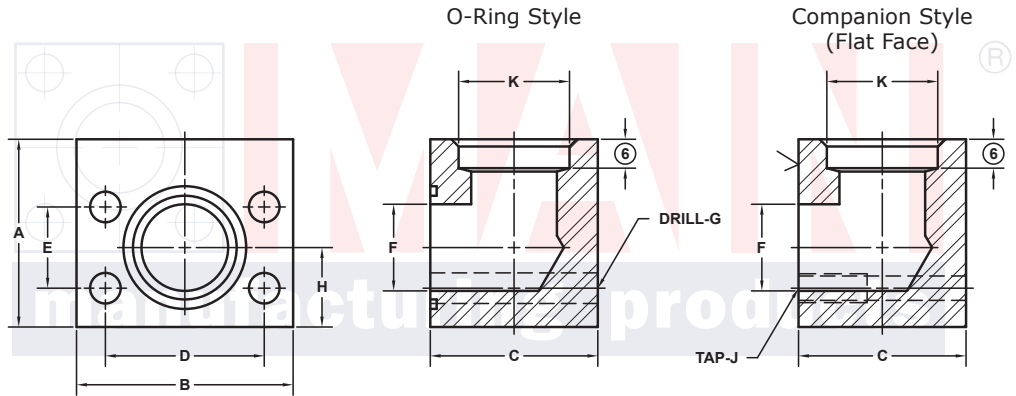
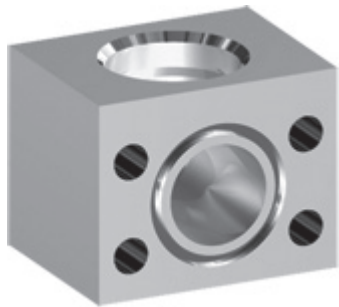

Model 1129 / 1131

Model 1130 / 1132

3181 TRI-PARK DR. GRAND BLANC, MI 48439 800-521-7918 810-953-1380 FAX 810-953-1385 INFO@MAINMFG.COM

SAE BOLT PATTERN										62 SERIES					
FLANGE SIZE	TUBE SIZE	PART NUMBER	A	B	C	D	E	F	G J	H	K	MOUNTING KIT®			WT
												PART NO.	SCREW SIZE	O-RING	
1/2	3/8	1131-08-06	2.00	2.22	1.46	1.594	.718	.50	.34	.88	.385	MK 541	5/16-18 x 2	210	1.6
		1132-08-06							5/16-18						
1/2	1/2	1131-08-08	2.00	2.22	1.46	1.594	.718	.50	.34	.88	.510	MK 541	5/16-18 x 2	210	1.6
		1132-08-08							5/16-18						
1/2	3/4	1131-08-12	2.00	2.22	1.46	1.594	.718	.50	.34	.88	.760	MK 541	5/16-18 x 2	210	1.5
		1132-08-12							5/16-18						
3/4	3/4	1131-12-12	2.25	2.81	1.70	2.000	.937	.75	.41	1.00	.760	MK 542	3/8-16 x 2 1/2	214	2.6
		1132-12-12							3/8-16						
3/4	7/8	1131-12-14	2.25	2.81	1.70	2.000	.937	.75	.41	1.00	.885	MK 542	3/8-16 x 2 1/2	214	2.5
		1132-12-14							3/8-16						
3/4	1	1131-12-16	2.25	2.81	1.70	2.000	.937	.75	.41	1.00	1.010	MK 542	3/8-16 x 2 1/2	214	2.4
		1132-12-16							3/8-16						
1	1	1131-16-16	2.50	3.19	2.21	2.250	1.093	1.00	.47	1.12	1.010	MK 2533	7/16-14 x 3	219	4.1
		1132-16-16							7/16-14						
1	1 1/4	1131-16-20	2.50	3.19	2.21	2.250	1.093	1.00	.47	1.12	1.260	MK 2533	7/16-14 x 3	219	4.0
		1132-16-20							7/16-14						

① Order Separately

⑥ C'bore Depth by Tube Size: 3/8" to 3/4" is .38"; 7/8" to 1 1/4" is .50"

SOCKET WELD TUBE ELBOW FLANGES (Pg 2/2)

SAE BOLT PATTERN										61 SERIES					
FLANGE SIZE	TUBE SIZE	PART NUMBER	A	B	C	D	E	F	G J	H	K	MOUNTING KIT®			WT
												PART NO.	SCREW SIZE	O-RING	
1 1/4	1	1129-20-16	2.75	3.19	2.40	2.312	1.188	1.25	.47	1.25	1.010	MK 578	7/16-14 x 3 1/4	222	4.7
		1130-20-16							7/16-14						
1 1/4	1 1/4	1129-20-20	2.75	3.19	2.40	2.312	1.188	1.25	.47	1.25	1.260	MK 578	7/16-14 x 3 1/4	222	4.6
		1130-20-20							7/16-14						
1 1/4	1 1/2	1129-20-24	2.75	3.19	2.40	2.312	1.188	1.25	.47	1.25	1.510	MK 578	7/16-14 x 3 1/4	222	4.4
		1130-20-24							7/16-14						
1 1/2	1 1/4	1129-24-20	3.00	3.75	2.90	2.750	1.406	1.50	.53	1.38	1.260	MK 545	1/2-13 x 4	225	7.2
		1130-24-20							1/2-13						
1 1/2	1 1/2	1129-24-24	3.00	3.75	2.90	2.750	1.406	1.50	.53	1.38	1.510	MK 545	1/2-13 x 4	225	7.0
		1130-24-24							1/2-13						
1 1/2	1 3/4	1129-24-28	3.00	3.75	2.90	2.750	1.406	1.50	.53	1.38	1.760	MK 545	1/2-13 x 4	225	6.8
		1130-24-28							1/2-13						
1 1/2	2	1129-24-32	3.00	3.75	2.90	2.750	1.406	1.50	.53	1.38	2.010	MK 545	1/2-13 x 4	225	6.7
		1130-24-32							1/2-13						
2	1 1/2	1129-32-24	3.50	4.00	3.40	3.062	1.688	1.94	.53	1.62	1.510	MK 546	1/2-13 x 4 1/2	228	10.3
		1130-32-24							1/2-13						
2	1 3/4	1129-32-28	3.50	4.00	3.40	3.062	1.688	1.94	.53	1.62	1.760	MK 546	1/2-13 x 4 1/2	228	10.0
		1130-32-28							1/2-13						
2	2	1129-32-32	3.50	4.00	3.40	3.062	1.688	1.94	.53	1.62	2.010	MK 546	1/2-13 x 4 1/2	228	9.9
		1130-32-32							1/2-13						
2	2 1/4	1129-32-36	3.50	4.00	3.40	3.062	1.688	1.94	.53	1.62	2.260	MK 546	1/2-13 x 4 1/2	228	9.3
		1130-32-36							1/2-13						

MATERIAL:
Low Carbon Steel

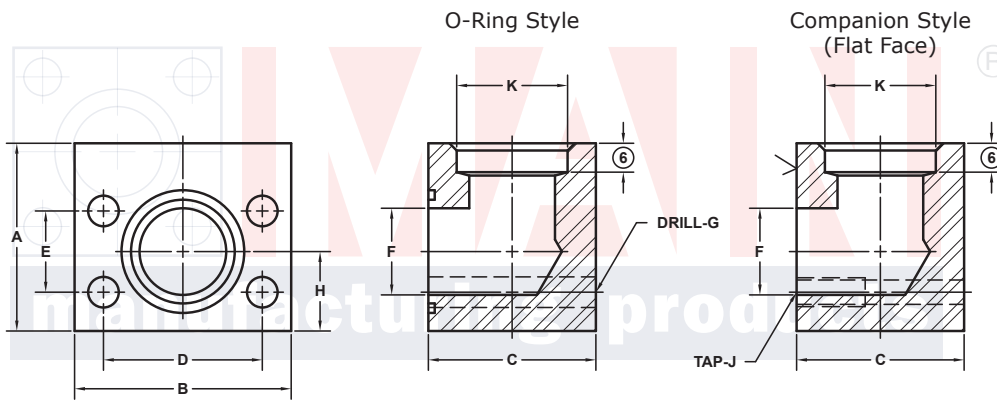

Model 1129 / 1131

Model 1130 / 1132

3181 TRI-PARK DR. GRAND BLANC, MI 48439 800-521-7918 810-953-1380 FAX 810-953-1385 INFO@MAINMFG.COM

SAE BOLT PATTERN										62 SERIES					
FLANGE SIZE	TUBE SIZE	PART NUMBER	A	B	C	D	E	F	G J	H	K	MOUNTING KIT®			WT
												PART NO.	SCREW SIZE	O-RING	
1 1/4	1	1131-20-16	3.00	3.75	2.44	2.625	1.250	1.25	.53	1.38	1.010	MK 552	1/2-13 x 3 1/4	222	6.4
		1132-20-16							1/2-13						
1 1/4	1 1/4	1131-20-20	3.00	3.75	2.44	2.625	1.250	1.25	.53	1.38	1.260	MK 552	1/2-13 x 3 1/4	222	6.3
		1132-20-20							1/2-13						
1 1/4	1 1/2	1131-20-24	3.00	3.75	2.44	2.625	1.250	1.25	.53	1.38	1.510	MK 552	1/2-13 x 3 1/4	222	6.1
		1132-20-24							1/2-13						
1 1/2	1 1/2	1131-24-24	3.50	4.50	2.96	3.125	1.437	1.50	.66	1.62	1.510	MK 553	5/8-11 x 4	225	10.5
		1132-24-24							5/8-11						
1 1/2	1 3/4	1131-24-28	3.50	4.50	2.96	3.125	1.437	1.50	.66	1.62	1.760	MK 553	5/8-11 x 4	225	10.2
		1132-24-28							5/8-11						
1 1/2	2	1131-24-32	3.50	4.50	2.96	3.125	1.437	1.50	.66	1.62	2.010	MK 553	5/8-11 x 4	225	10.1
		1132-24-32							5/8-11						
2	2	1131-32-32	4.00	5.25	3.46	3.812	1.750	1.94	.78	2.00	2.010	MK 554	3/4-10 x 4 1/2	228	15.9
		1132-32-32							3/4-10						
2	2 1/4	1131-32-36	4.00	5.25	3.46	3.812	1.750	1.94	.78	2.00	2.260	MK 554	3/4-10 x 4 1/2	228	15.3
		1132-32-36							3/4-10						

① Order Separately ② 2500 PSI Max ③ 2000 PSI Max ④ 500 PSI Max
 ® C'bore Depth by Tube Size: 1" to 2 1/4" is .50"