

SOCKET WELD PIPE ELBOW FLANGES (Pg 1/2)

SAE BOLT PATTERN			61 SERIES												
FLANGE SIZE	PIPE SIZE	PART NUMBER	A	B	C	D	E	F	G	H	K	MOUNTING KIT®			WT
									J			PART NO.	SCREW SIZE	O-RING	
1/2	1/2	1125-08-08	1.75	2.12	1.44	1.500	.688	.50	.34	.75	.860	MK 541	5/16-18 x 2	210	1.3
		1126-08-08							5/16-18						
3/4	1/2	1125-12-08	2.00	2.62	1.70	1.875	.875	.75	.41	.88	.860	MK 542	3/8-16 x 2 1/2	214	2.1
		1126-12-08							3/8-16						
3/4	3/4	1125-12-12	2.00	2.62	1.70	1.875	.875	.75	.41	.88	1.070	MK 542	3/8-16 x 2 1/2	214	2.0
		1126-12-12							3/8-16						
1	3/4	1125-16-12	2.25	2.82	1.94	2.062	1.031	1.00	.41	1.00	1.070	MK 543	3/8-16 x 2 3/4	219	2.8
		1126-16-12							3/8-16						
1	1	1125-16-16	2.25	2.82	1.94	2.062	1.031	1.00	.41	1.00	1.335	MK 543	3/8-16 x 2 3/4	219	2.7
		1126-16-16							3/8-16						
1 1/4	1	1125-20-16	2.75	3.19	2.40	2.312	1.188	1.25	.47	1.25	1.335	MK 578	7/16-14 x 3 1/4	222	4.9
		1126-20-16							7/16-14						
1 1/4	1 1/4	1125-20-20	2.75	3.19	2.40	2.312	1.188	1.25	.47	1.25	1.680	MK 578	7/16-14 x 3 1/4	222	4.8
		1126-20-20							7/16-14						
1 1/4	1 1/2	1125-20-24	3.00	3.19	3.00	2.312	1.188	1.25	.47	1.25	1.920	MK 591	7/16-14 x 4	222	6.0
		1126-20-24							7/16-14						
1 1/2	1 1/4	1125-24-20	3.00	3.75	2.90	2.750	1.406	1.50	.53	1.38	1.680	MK 545	1/2-13 x 4	225	7.4
		1126-24-20							1/2-13						
1 1/2	1 1/2	1125-24-24	3.00	3.75	2.90	2.750	1.406	1.50	.53	1.38	1.920	MK 545	1/2-13 x 4	225	7.3
		1126-24-24							1/2-13						
1 1/2	2	1125-24-32	3.50	3.75	3.50	2.750	1.406	1.50	.53	1.38	2.411	MK 579	1/2-13 x 4 1/2	225	9.8
		1126-24-32							1/2-13						

MATERIAL:
Low Carbon Steel

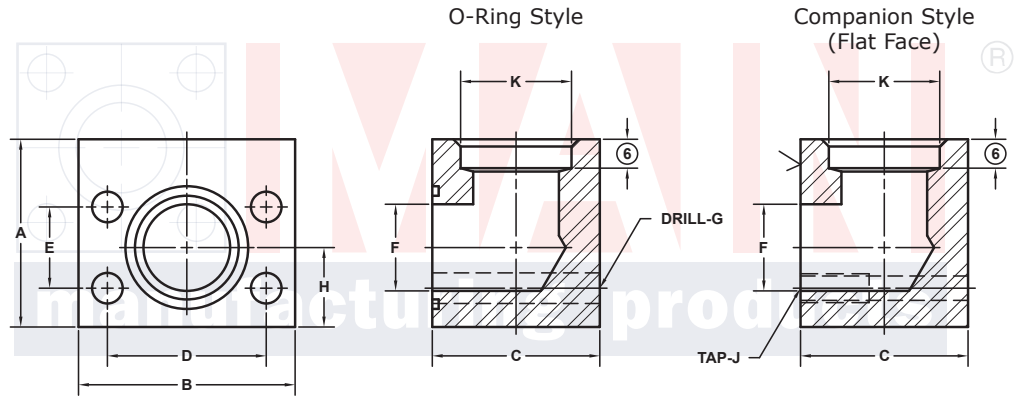
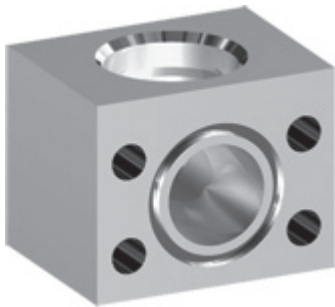

Model 1125 / 1127

Model 1126 / 1128

3181 TRI-PARK DR. GRAND BLANC, MI 48439 800-521-7918 810-953-1380 FAX 810-953-1385 INFO@MAINMFG.COM

SAE BOLT PATTERN			62 SERIES												
FLANGE SIZE	PIPE SIZE	PART NUMBER	A	B	C	D	E	F	G	H	K	MOUNTING KIT®			WT
									J			PART NO.	SCREW SIZE	O-RING	
1/2	1/2	1127-08-08	2.00	2.22	1.46	1.594	.718	.50	.34	.88	.860	MK 541	5/16-18 x 2	210	1.6
		1128-08-08							5/16-18						
3/4	1/2	1127-12-08	2.25	2.81	1.70	2.000	.937	.75	.41	1.00	.860	MK 542	3/8-16 x 2 1/2	214	2.7
		1128-12-08							3/8-16						
3/4	3/4	1127-12-12	2.25	2.81	1.70	2.000	.937	.75	.41	1.00	1.070	MK 542	3/8-16 x 2 1/2	214	2.6
		1128-12-12							3/8-16						
1	3/4	1127-16-12	2.50	3.19	2.21	2.250	1.093	1.00	.47	1.12	1.070	MK 2533	7/16-14 x 3	219	4.2
		1128-16-12							7/16-14						
1	1	1127-16-16	2.50	3.19	2.21	2.250	1.093	1.00	.47	1.12	1.335	MK 2533	7/16-14 x 3	219	4.1
		1128-16-16							7/16-14						
1 1/4	1	1127-20-16	3.00	3.75	2.44	2.625	1.250	1.25	.53	1.38	1.335	MK 552	1/2-13 x 3 1/4	222	6.5
		1128-20-16							1/2-13						
1 1/4	1 1/4	1127-20-20	3.00	3.75	2.44	2.625	1.250	1.25	.53	1.38	1.680	MK 552	1/2-13 x 3 1/4	222	6.3
		1128-20-20							1/2-13						
1 1/4	1 1/2	1127-20-24	3.00	3.75	3.00	2.625	1.250	1.25	.53	1.38	1.920	MK 587	1/2-13 x 4	222	7.6
		1128-20-24							1/2-13						

① Order Separately

⑥ C'bore Depth by Pipe Size: 1/2" is .38"; 3/4" to 2" is .50"

SOCKET WELD PIPE ELBOW FLANGES (Pg 2/2)

SAE BOLT PATTERN										61 SERIES					
FLANGE SIZE	PIPE SIZE	PART NUMBER	A	B	C	D	E	F	G J	H	K	MOUNTING KIT®			WT
												PART NO.	SCREW SIZE	O-RING	
2	1 1/4	1125-32-20	3.50	4.00	3.40	3.062	1.688	1.94	.53	1.62	1.680	MK 546	1/2-13 x 4 1/2	228	10.4
		1126-32-20							1/2-13						
2	1 1/2	1125-32-24	3.50	4.00	3.40	3.062	1.688	1.94	.53	1.62	1.920	MK 546	1/2-13 x 4 1/2	228	10.2
		1126-32-24							1/2-13						
2	2	1125-32-32	3.50	4.00	3.40	3.062	1.688	1.94	.53	1.62	2.411	MK 546	1/2-13 x 4 1/2	228	9.9
		1126-32-32							1/2-13						
2 1/2 ^②	2	1125-40-32	4.00	4.50	3.96	3.500	2.000	2.44	.53	2.00	2.411	MK 547	1/2-13 x 5	232	14.9
		1126-40-32							1/2-13						
2 1/2 ^②	2 1/2	1125-40-40	4.00	4.50	3.96	3.500	2.000	2.44	.53	2.00	2.911	MK 547	1/2-13 x 5	232	13.9
		1126-40-40							1/2-13						
3 ^③	2 1/2	1125-48-40	5.00	5.31	4.96	4.188	2.438	2.94	.66	2.25	2.911	MK 548	5/8-11 x 6	237	26.5
		1126-48-40							5/8-11						
3 ^③	3	1125-48-48	5.00	5.31	4.96	4.188	2.438	2.94	.66	2.25	3.540	MK 548	5/8-11 x 6	237	24.9
		1126-48-48							5/8-11						
3 1/2 ^④	3	1125-56-48	5.50	6.00	5.40	4.750	2.750	3.44	.66	2.50	3.540	MK 549	5/8-11 x 6 1/2	241	36.8
		1126-56-48							5/8-11						
3 1/2 ^④	3 1/2	1125-56-56	5.50	6.00	5.40	4.750	2.750	3.44	.66	2.50	4.045	MK 549	5/8-11 x 6 1/2	241	34.8
		1126-56-56							5/8-11						
4 ^④	4	1125-64-64	6.00	6.38	5.96	5.125	3.062	3.94	.66	2.75	4.550	MK 550	5/8-11 x 7	245	41.9
		1126-64-64							5/8-11						
5 ^④	5	1125-80-80	7.00	7.25	6.90	6.000	3.625	4.94	.66	3.38	5.635	MK 1569	5/8-11 x 8	253	60.9
		1126-80-80							5/8-11						

MATERIAL:
Low Carbon Steel

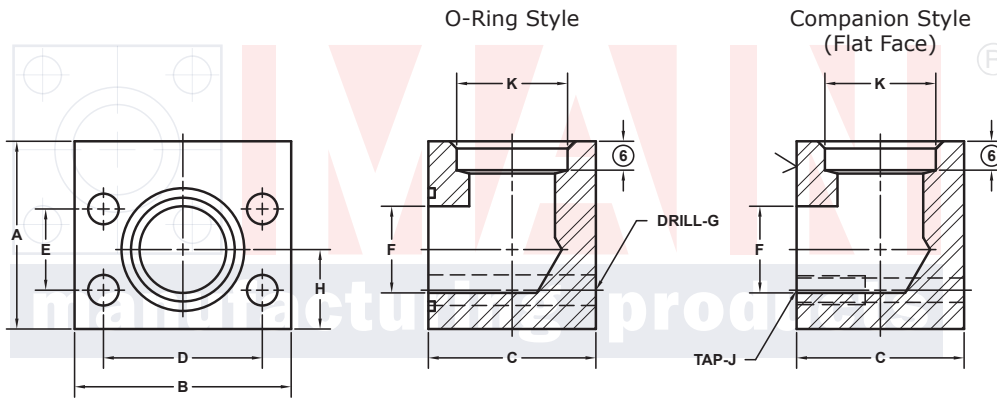

Model 1125 / 1127

Model 1126 / 1128

3181 TRI-PARK DR. GRAND BLANC, MI 48439 800-521-7918 810-953-1380 FAX 810-953-1385 INFO@MAINMFG.COM

SAE BOLT PATTERN										62 SERIES					
FLANGE SIZE	PIPE SIZE	PART NUMBER	A	B	C	D	E	F	G J	H	K	MOUNTING KIT®			WT
												PART NO.	SCREW SIZE	O-RING	
1 1/2	1 1/4	1127-24-20	3.50	4.50	2.96	3.125	1.437	1.50	.66	1.62	1.680	MK 553	5/8-11 x 4	225	11.0
		1128-24-20							5/8-11						
1 1/2	1 1/2	1127-24-24	3.50	4.50	2.96	3.125	1.437	1.50	.66	1.62	1.920	MK 553	5/8-11 x 4	225	10.7
		1128-24-24							5/8-11						
1 1/2	2	1127-24-32	3.50	4.50	3.50	3.125	1.437	1.50	.66	1.62	2.411	MK 1587	5/8-11 x 4 1/2	225	12.2
		1128-24-32							5/8-11						
2	1 1/2	1127-32-24	4.00	5.25	3.46	3.812	1.750	1.94	.78	2.00	1.920	MK 554	3/4-10 x 4 1/2	228	16.5
		1128-32-24							3/4-10						
2	2	1127-32-32	4.00	5.25	3.46	3.812	1.750	1.94	.78	2.00	2.411	MK 554	3/4-10 x 4 1/2	228	15.9
		1128-32-32							3/4-10						
2 1/2	2	1127-40-32	5.50	6.88	4.50	4.875	2.312	2.44	.94	2.50	2.411	MK 2557	7/8-9 x 6	232	40.0
		1128-40-32							7/8-9						
2 1/2	2 1/2	1127-40-40	5.50	6.88	4.50	4.875	2.312	2.44	.94	2.50	2.911	MK 2557	7/8-9 x 6	232	38.6
		1128-40-40							7/8-9						
3	3	1127-48-48	6.00	8.50	5.00	6.000	2.812	2.94	1.19	3.00	3.540	MK 756	1 1/8-7 x 7	237	56.5
		1128-48-48							1 1/8-7						

① Order Separately

② 2500 PSI Max ③ 2000 PSI Max ④ 500 PSI Max

⑥ C'bore Depth by Pipe Size: 1 1/4" to 2 1/2" is .50" (2 1/2" 62 Series is .62"); 3" to 5" is .62"