

SAE J1926 THREADED BRANCH TEE FLANGES

SAE J518 61 SERIES / ISO6162-1 PATTERN

FLANGE SIZE	ORB	PART NUMBER	A	B	C	D	E	F	Gmm		H	K	MOUNTING KIT®			WT
									Jmm				PART NO.	SCREW SIZE	O-RING	
1/2	-8	1157-08-08M8	2.50	2.12	1.44	1.500	.688	.50	8.5	M8x1.25	1.25	3/4-16	MKM 541	M8 x 50	210	1.7
		1158-08-08M8							-----				-----	---		
3/4	-10	1157-12-10M10	3.00	2.62	1.70	1.875	.875	.50	10.5	M10x1.5	1.50	7/8-14	MKM 542	M10 x 60	214	3.0
		1158-12-10M10							-----				-----	---		
3/4	-12	1157-12-12M10	3.00	2.62	1.70	1.875	.875	.75	10.5	M10x1.5	1.50	1 1/16-12	MKM 542	M10 x 60	214	2.8
		1158-12-12M10							-----				-----	---		
1	-14	1157-16-14M10	4.00	2.82	1.94	2.062	1.031	.75	10.5	M10x1.5	2.00	1 3/16-12	MKM 543	M10 x 65	219	4.7
		1158-16-14M10							-----				-----	---		
1	-16	1157-16-16M10	4.00	2.82	1.94	2.062	1.031	1.00	10.5	M10x1.5	2.00	1 5/16-12	MKM 543	M10 x 65	219	4.6
		1158-16-16M10							-----				-----	---		
1 1/4	-20	1157-20-20M10†	4.50	3.19	2.40	2.312	1.188	1.25	10.5	M10x1.5	2.25	1 5/8-12	MKM 4532	M10 x 75	222	7.0
		1158-20-20M10†							-----				-----	---		
1 1/2	-20	1157-24-20M12‡	4.50	3.75	2.90	2.750	1.406	1.50	13.0	M12x1.75	2.25	1 5/8-12	MKM 4533	M12 x 90	225	10.3
		1158-24-20M12‡							-----				-----	---		
1 1/2	-24	1157-24-24M12‡	4.50	3.75	2.90	2.750	1.406	1.50	13.0	M12x1.75	2.25	1 7/8-12	MKM 4533	M12 x 90	225	9.8
		1158-24-24M12‡							-----				-----	---		
2	-20	1157-32-20M12‡	5.25	4.00	2.94	3.062	1.688	1.94	13.0	M12x1.75	2.62	1 5/8-12	MKM 4547	M12 x 90	228	13.2
		1158-32-20M12‡							-----				-----	---		
2	-24	1157-32-24M12‡	5.25	4.00	2.94	3.062	1.688	1.94	13.0	M12x1.75	2.62	1 7/8-12	MKM 4547	M12 x 90	228	12.7
		1158-32-24M12‡							-----				-----	---		
2	-32	1157-32-32M12‡	5.25	4.00	3.94	3.062	1.688	1.94	13.0	M12x1.75	2.62	2 1/2-12	MKM 3550	M12 x 120	228	15.7
		1158-32-32M12‡							-----				-----	---		

MATERIAL:
Low Carbon Steel[®]

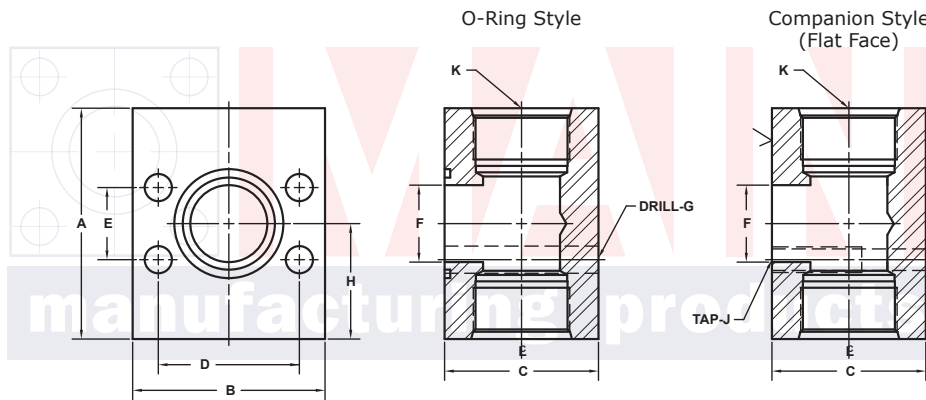
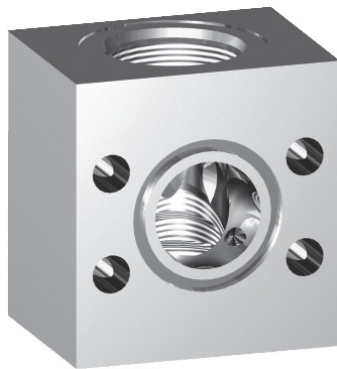

Model 1157 / 1159

Model 1158 / 1160

3181 TRI-PARK DR. GRAND BLANC, MI 48439 800-521-7918 810-953-1380 FAX 810-953-1385 INFO@MAINMFG.COM

SAE J518 62 SERIES / ISO6162-2 PATTERN

FLANGE SIZE	ORB	PART NUMBER	A	B	C	D	E	F	Gmm		H	K	MOUNTING KIT®			WT
									Jmm				PART NO.	SCREW SIZE	O-RING	
1/2	-8	1159-08-08M8	2.50	2.22	1.46	1.594	.718	.50	8.5	M8x1.25	1.25	3/4-16	MKM 541	M8 x 50	210	1.8
		1160-08-08M8							-----				-----	---		
3/4	-10	1159-12-10M10	3.00	2.81	1.70	2.000	.937	.50	10.5	M10x1.5	1.50	7/8-14	MKM 542	M10 x 60	214	3.3
		1160-12-10M10							-----				-----	---		
3/4	-12	1159-12-12M10	3.00	2.81	1.70	2.000	.937	.75	10.5	M10x1.5	1.50	1 1/16-12	MKM 542	M10 x 60	214	3.1
		1160-12-12M10							-----				-----	---		
1	-14	1159-16-14M12	4.00	3.19	1.96	2.250	1.093	.75	12.5	M12x1.75	2.00	1 3/16-12	MKM 551	M12 x 70	219	5.5
		1160-16-14M12							-----				-----	---		
1	-16	1159-16-16M12	4.00	3.19	1.96	2.250	1.093	1.00	12.5	M12x1.75	2.00	1 5/16-12	MKM 551	M12 x 70	219	5.4
		1160-16-16M12							-----				-----	---		
1 1/4	-20	1159-20-20M12‡	4.50	3.75	2.44	2.625	1.250	1.25	13.0	M12x1.75	2.25	1 5/8-12	MKM 578	M12 x 80	222	9.0
		1160-20-20M12‡							-----				-----	---		
1 1/2	-24	1159-24-24M16	4.50	4.50	2.96	3.125	1.437	1.50	17.0	M16x2	2.25	1 7/8-12	MKM 553	M16 x 100	225	12.7
		1160-24-24M16							-----				-----	---		
2	-32	1159-32-32M20	6.00	5.25	3.94	3.812	1.750	1.94	21.0	M20x2.5	3.00	2 1/2-12	MKM 1507	M20 x 130	228	25.8
		1160-32-32M20							-----				-----	---		

① Order Separately

® May Contain Lead

NOTE: The Pressure Rating of the Assembly Should NOT Exceed the Lower of the Flange Pad or the Fitting. Check the Fitting Manufacturer for Details.