

# NPTF THREADED ELBOW FLANGES (Pg 1/2)

SAE BOLT PATTERN										61 SERIES					
FLANGE SIZE	PIPE SIZE	PART NUMBER	A	B	C	D	E	F	G J	H	K NPTF	MOUNTING KIT®			WT
												PART NO.	SCREW SIZE	O-RING	
1/2	1/2	1161-08-08	2.00	2.12	1.44	1.500	.688	.50	.34	.75	1/2	MK 541	5/16-18 x 2	210	1.5
		1162-08-08							5/16-18						
3/4	1/2	1161-12-08	2.50	2.62	1.70	1.875	.875	.75	.41	.88	1/2	MK 542	3/8-16 x 2 1/2	214	2.7
		1162-12-08							3/8-16						
3/4	3/4	1161-12-12	2.50	2.62	1.70	1.875	.875	.75	.41	.88	3/4	MK 542	3/8-16 x 2 1/2	214	2.6
		1162-12-12							3/8-16						
1	3/4	1161-16-12	3.00	2.82	1.94	2.062	1.031	1.00	.41	1.00	3/4	MK 543	3/8-16 x 2 3/4	219	3.9
		1162-16-12							3/8-16						
1	1	1161-16-16	3.00	2.82	1.94	2.062	1.031	1.00	.41	1.00	1	MK 543	3/8-16 x 2 3/4	219	3.5
		1162-16-16							3/8-16						
1 1/4	1	1161-20-16	3.50	3.19	2.40	2.312	1.188	1.25	.47	1.25	1	MK 578	7/16-14 x 3 1/4	222	6.5
		1162-20-16							7/16-14						
1 1/4	1 1/4	1161-20-20	3.50	3.19	2.40	2.312	1.188	1.25	.47	1.25	1 1/4	MK 578	7/16-14 x 3 1/4	222	6.2
		1162-20-20							7/16-14						
1 1/4	1 1/2	1161-20-24	4.00	3.19	3.00	2.312	1.188	1.25	.47	1.25	1 1/2	MK 591	7/16-14 x 4	222	6.0
		1162-20-24							7/16-14						
1 1/2	1 1/4	1161-24-20	4.00	3.75	2.90	2.750	1.406	1.50	.53	1.38	1 1/4	MK 545	1/2-13 x 4	225	10.0
		1162-24-20							1/2-13						
1 1/2	1 1/2	1161-24-24	4.00	3.75	2.90	2.750	1.406	1.50	.53	1.38	1 1/2	MK 545	1/2-13 x 4	225	9.9
		1162-24-24							1/2-13						
1 1/2	2	1161-24-32	4.00	3.75	2.90	2.750	1.406	1.50	.53	1.38	2	MK 545	1/2-13 x 4	225	8.9
		1162-24-32							1/2-13						

MATERIAL:  
Low Carbon Steel®

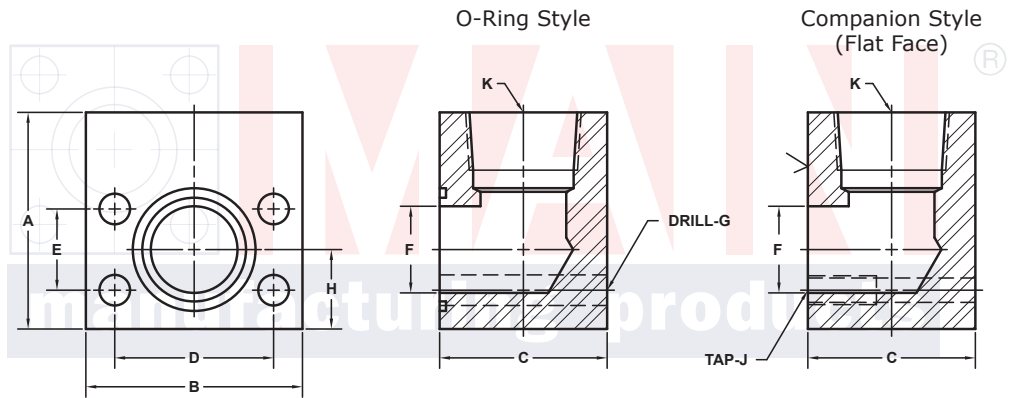
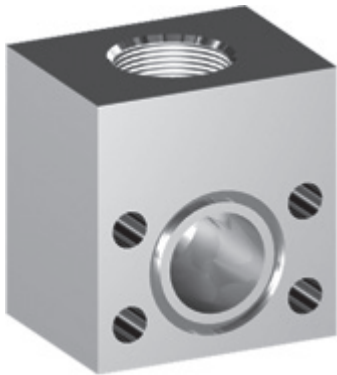

Model 1161 / 1163

Model 1162 / 1164

3181 TRI-PARK DR. GRAND BLANC, MI 48439 800-521-7918 810-953-1380 FAX 810-953-1385 INFO@MAINMFG.COM

SAE BOLT PATTERN										62 SERIES					
FLANGE SIZE	PIPE SIZE	PART NUMBER	A	B	C	D	E	F	G J	H	K NPTF	MOUNTING KIT®			WT
												PART NO.	SCREW SIZE	O-RING	
1/2	1/2	1163-08-08	2.00	2.22	1.46	1.594	.718	.50	.34	.88	1/2	MK 541	5/16-18 x 2	210	1.6
		1164-08-08							5/16-18						
3/4	1/2	1163-12-08	2.50	2.81	1.70	2.000	.937	.75	.41	1.00	1/2	MK 542	3/8-16 x 2 1/2	214	2.9
		1164-12-08							3/8-16						
3/4	3/4	1163-12-12	2.50	2.81	1.70	2.000	.937	.75	.41	1.00	3/4	MK 542	3/8-16 x 2 1/2	214	2.8
		1164-12-12							3/8-16						
1	3/4	1163-16-12	3.00	3.19	1.96	2.250	1.093	1.00	.47	1.12	3/4	MK 551	7/16-14 x 2 3/4	219	4.6
		1164-16-12							7/16-14						
1	1	1163-16-16	3.00	3.19	1.96	2.250	1.093	1.00	.47	1.12	1	MK 551	7/16-14 x 2 3/4	219	4.4
		1164-16-16							7/16-14						
1 1/4	1	1163-20-16	4.00	3.75	2.44	2.625	1.250	1.25	.53	1.38	1	MK 552	1/2-13 x 3 1/4	222	6.9
		1164-20-16							1/2-13						
1 1/4	1 1/4	1163-20-20	4.00	3.75	2.44	2.625	1.250	1.25	.53	1.38	1 1/4	MK 552	1/2-13 x 3 1/4	222	6.7
		1164-20-20							1/2-13						
1 1/4	1 1/2	1163-20-24	4.00	3.75	3.00	2.625	1.250	1.25	.53	1.38	1 1/2	MK 587	1/2-13 x 4	222	9.9
		1164-20-24							1/2-13						

① Order Separately

⑤ May Contain Lead

# NPTF THREADED ELBOW FLANGES (Pg 2/2)

SAE BOLT PATTERN										61 SERIES					
FLANGE SIZE	PIPE SIZE	PART NUMBER	A	B	C	D	E	F	G J	H	K NPTF	MOUNTING KIT®			WT
												PART NO.	SCREW SIZE	O-RING	
2	1 1/4	1161-32-20	4.50	4.00	2.96	3.062	1.688	1.94	.53	1.62	1 1/4	MK 558	1/2-13 x 4	228	11.3
		1162-32-20							1/2-13						
2	1 1/2	1161-32-24	4.50	4.00	2.96	3.062	1.688	1.94	.53	1.62	1 1/2	MK 558	1/2-13 x 4	228	10.9
		1162-32-24							1/2-13						
2	2	1161-32-32	4.50	4.00	2.96	3.062	1.688	1.94	.53	1.62	2	MK 558	1/2-13 x 4	228	10.7
		1162-32-32							1/2-13						
2 1/2 <sup>②</sup>	1 1/2	1161-40-24	5.00	4.50	3.96	3.500	2.000	2.44	.53	2.00	1 1/2	MK 547	1/2-13 x 5	232	18.5
		1162-40-24							1/2-13						
2 1/2 <sup>②</sup>	2	1161-40-32	5.00	4.50	3.96	3.500	2.000	2.44	.53	2.00	2	MK 547	1/2-13 x 5	232	17.8
		1162-40-32							1/2-13						
2 1/2 <sup>②</sup>	2 1/2	1161-40-40	5.00	4.50	3.96	3.500	2.000	2.44	.53	2.00	2 1/2	MK 547	1/2-13 x 5	232	17.5
		1162-40-40							1/2-13						
3 <sup>③</sup>	2	1161-48-32	6.00	5.31	4.46	4.188	2.438	2.94	.66	2.25	2	MK 2532	5/8-11 x 5 1/2	237	29.6
		1162-48-32							5/8-11						
3 <sup>③</sup>	2 1/2	1161-48-40	6.00	5.31	4.46	4.188	2.438	2.94	.66	2.25	2 1/2	MK 2532	5/8-11 x 5 1/2	237	30.0
		1162-48-40							5/8-11						
3 <sup>③</sup>	3	1161-48-48	6.00	5.31	4.46	4.188	2.438	2.94	.66	2.25	3	MK 2532	5/8-11 x 5 1/2	237	27.6
		1162-48-48							5/8-11						
3 1/2 <sup>④</sup>	3	1161-56-48	6.00	6.00	5.00	4.750	2.750	3.44	.66	2.50	3	MK 5543	5/8-11 x 6	241	36.8
		1162-56-48							5/8-11						
3 1/2 <sup>④</sup>	3 1/2	1161-56-56	6.25	6.00	5.40	4.750	2.750	3.44	.66	2.50	3 1/2	MK 549	5/8-11 x 6 1/2	241	40.0
		1162-56-56							5/8-11						

**MATERIAL:**  
**Low Carbon Steel**®

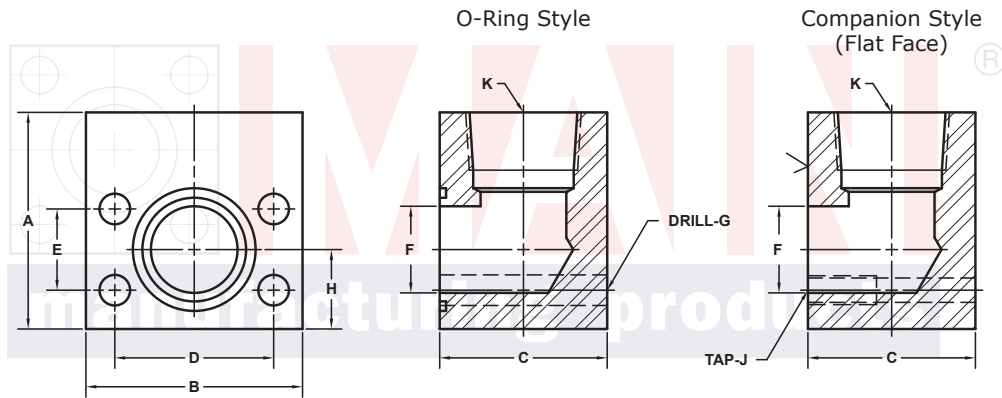

Model 1161 / 1163

Model 1162 / 1164



3181 TRI-PARK DR. GRAND BLANC, MI 48439 800-521-7918 810-953-1380 FAX 810-953-1385 INFO@MAINMFG.COM

SAE BOLT PATTERN										62 SERIES					
FLANGE SIZE	PIPE SIZE	PART NUMBER	A	B	C	D	E	F	G J	H	K NPTF	MOUNTING KIT®			WT
												PART NO.	SCREW SIZE	O-RING	
1 1/2	1 1/4	1163-24-20	4.00	4.50	2.96	3.125	1.437	1.50	.66	1.62	1 1/4	MK 553	5/8-11 x 4	225	12.5
		1164-24-20							5/8-11						
1 1/2	1 1/2	1163-24-24	4.00	4.50	2.96	3.125	1.437	1.50	.66	1.62	1 1/2	MK 553	5/8-11 x 4	225	11.9
		1164-24-24							5/8-11						
1 1/2	2	1163-24-32	4.50	4.50	3.50	3.125	1.437	1.50	.66	1.62	2	MK 1587	5/8-11 x 4 1/2	225	15.3
		1164-24-32							5/8-11						
2	1 1/2	1163-32-24	5.00	5.25	3.46	3.812	1.750	1.94	.78	2.00	1 1/2	MK 554	3/4-10 x 4 1/2	228	20.7
		1164-32-24							3/4-10						
2	2	1163-32-32	5.00	5.25	3.46	3.812	1.750	1.94	.78	2.00	2	MK 554	3/4-10 x 4 1/2	228	20.2
		1164-32-32							3/4-10						
2 1/2	2	1163-40-32	6.00	6.88	4.00	4.875	2.312	2.44	.94	2.50	2	MK 555	7/8-9 x 5 1/2	232	39.0
		1164-40-32							7/8-9						
2 1/2	2 1/2	1163-40-40	6.00	6.88	4.00	4.875	2.312	2.44	.94	2.50	2 1/2	MK 555	7/8-9 x 5 1/2	232	37.9
		1164-40-40							7/8-9						
3	3	1163-48-48	7.00	8.50	5.00	6.000	2.812	2.94	1.19	3.00	3	MK 756	1 1/8-7 x 7	237	63.7
		1164-48-48							1 1/8-7						

① Order Separately

② 2500 PSI Max

③ 2000 PSI Max

④ 500 PSI Max

⑤ May Contain Lead