

ISO 6149 THREADED ELBOW FLANGES

SAE J518 61 SERIES / ISO6162-1 PATTERN

FLANGE SIZE	PORT SIZE	PART NUMBER	A	B	C	D	E	F	Gmm	H	K	MOUNTING KIT ^①			WT
									Jmm			PART NO.	SCREW SIZE	O-RING	
1/2	-8	1605-08-08M8	2.00	2.12	1.44	1.500	.688	.50	8.5	.75	M18x1.5	MKM 541	M8 x 50	210	1.5
		M8x1.25							-----			-----	---		
3/4	-10	1605-12-10M10	2.50	2.62	1.70	1.875	.875	.75	10.5	.88	M22x1.5	MKM 542	M10 x 60	214	2.7
		M10x1.5							-----			-----	---		
3/4	-12	1605-12-12M10	2.50	2.62	1.70	1.875	.875	.75	10.5	.88	M27x2.0	MKM 542	M10 x 60	214	2.5
		M10x1.5							-----			-----	---		
1	-12	1605-16-12M10	3.00	2.82	1.94	2.062	1.031	1.00	10.5	1.00	M27x2.0	MKM 543	M10 x 65	219	3.9
		M10x1.5							-----			-----	---		
1	-16	1605-16-16M10	3.00	2.82	1.94	2.062	1.031	1.00	10.5	1.00	M33x2.0	MKM 543	M10 x 65	219	3.7
		M10x1.5							-----			-----	---		
1 1/4	-20	1605-20-20M10†	3.50	3.19	2.40	2.312	1.188	1.25	10.5	1.25	M42x2.0	MKM 4532	M10 x 75	222	5.8
		M10x1.5							-----			-----	---		
1 1/2	-20	1605-24-20M12‡	4.00	3.75	2.90	2.750	1.406	1.50	13.0	1.38	M42x2.0	MKM 4533	M12 x 90	225	9.2
		M12x1.75							-----			-----	---		
1 1/2	-24	1605-24-24M12‡	4.00	3.75	2.90	2.750	1.406	1.50	13.0	1.38	M48x2.0	MKM 4533	M12 x 90	225	9.4
		M12x1.75							-----			-----	---		
2	-20	1605-32-20M12‡	4.50	4.00	2.96	3.062	1.688	1.94	13.0	1.62	M42x2.0	MKM 4547	M12 x 90	228	12.3
		M12x1.75							-----			-----	---		
2	-24	1605-32-24M12‡	4.50	4.00	2.96	3.062	1.688	1.94	13.0	1.62	M48x2.0	MKM 4547	M12 x 90	228	12.0
		M12x1.75							-----			-----	---		
2	-32	1605-32-32M12‡	4.25	4.00	3.40	3.062	1.688	1.94	13.0	1.62	M60x2.0	MKM 4534	M12 x 100	228	11.5
		M12x1.75							-----			-----	---		

MATERIAL:
Low Carbon Steel[®]

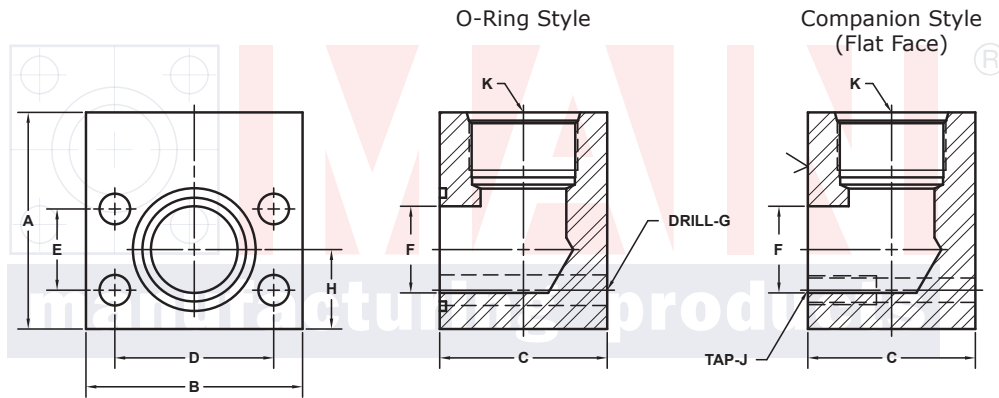

Model 1605 / 1607

Model 1606 / 1608

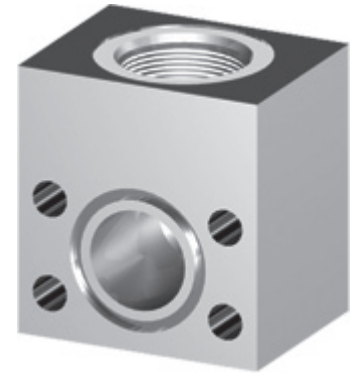

3181 TRI-PARK DR. GRAND BLANC, MI 48439 800-521-7918 810-953-1380 FAX 810-953-1385 INFO@MAINMFG.COM

SAE J518 62 SERIES / ISO6162-2 PATTERN

FLANGE SIZE	PORT SIZE	PART NUMBER	A	B	C	D	E	F	Gmm	H	K	MOUNTING KIT ^①			WT
									Jmm			PART NO.	SCREW SIZE	O-RING	
1/2	-8	1607-08-08M8	2.00	2.22	1.46	1.594	.718	.50	8.5	.88	M18x1.5	MKM 541	M8 x 50	210	1.6
		M8x1.25							-----			-----	---		
3/4	-10	1607-12-10M10	2.50	2.81	1.70	2.000	.937	.75	10.5	1.00	M22x1.5	MKM 542	M10 x 60	214	3.0
		M10x1.5							-----			-----	---		
3/4	-12	1607-12-12M10	2.50	2.81	1.70	2.000	.937	.75	10.5	1.00	M27x2.0	MKM 542	M10 x 60	214	2.8
		M10x1.5							-----			-----	---		
1	-12	1607-16-12M12	3.00	3.19	1.96	2.250	1.093	1.00	12.5	1.12	M27x2.0	MKM 551	M12 x 70	219	4.5
		M12x1.75							-----			-----	---		
1	-16	1607-16-16M12	3.00	3.19	1.96	2.250	1.093	1.00	12.5	1.12	M33x2.0	MKM 551	M12 x 70	219	4.3
		M12x1.75							-----			-----	---		
1 1/4	-20	1607-20-20M12‡	4.00	3.75	2.44	2.625	1.250	1.25	13.0	1.38	M42x2.0	MKM 578	M12 x 80	222	8.3
		M12x1.75							-----			-----	---		
1 1/2	-24	1607-24-24M16	4.00	4.50	2.96	3.125	1.437	1.50	17.0	1.62	M48x2.0	MKM 553	M16 x 100	225	12.0
		M16x2							-----			-----	---		
2	-32	1607-32-32M20	5.00	5.25	3.46	3.812	1.750	1.94	21.0	2.00	M60x2.0	MKM 554	M20 x 120	228	19.7
		M20x2.5							-----			-----	---		

① Order Separately

⑤ May Contain Lead

NOTE: The Pressure Rating of the Assembly Should NOT Exceed the Lower of the Flange Pad or the Fitting. Check the Fitting Manufacturer for Details.

NOTE: DIMENSIONS ARE IN INCHES UNLESS OTHERWISE NOTED. † Also Available for M12 Bolts ‡ Also Available for M14 Bolts

© Copyright MAIN Mfg. 2017