

SOCKET WELD TUBE FLANGED HEADS

61 SERIES

FLANGE SIZE	TUBE SIZE	PART NUMBER	A	B	C	D	E	F	G	H	K	L	O-RING NO. ①	WT
1/2	5/8	1237-08-10	2.12	1.188	1.31	.265	.92	.50	.50	.50	.635	1.000	210	.4
		1238-08-10										---	---	
1/2	3/4	1237-08-12	2.12	1.188	1.31	.265	.92	.50	.50	.50	.760	1.000	210	.4
		1238-08-12										---	---	
3/4	1	1237-12-16	2.25	1.500	1.62	.265	1.23	.75	.50	.50	1.010	1.250	214	.6
		1238-12-16										---	---	
1	1 1/4	1237-16-20	2.25	1.750	1.88	.315	1.48	1.00	.50	.50	1.260	1.562	219	.8
		1238-16-20										---	---	
1 1/4	1 1/2	1237-20-24	2.62	2.000	2.12	.315	1.69	1.25	.50	.50	1.510	1.750	222	1.0
		1238-20-24										---	---	
1 1/2	1 3/4	1237-24-28	2.75	2.375	2.50	.315	1.97	1.50	.50	.50	1.760	2.125	225	1.4
		1238-24-28										---	---	
1 1/2	2	1237-24-32	2.75	2.375	2.50	.315	1.97	1.50	.50	.50	2.010	2.125	225	1.3
		1238-24-32										---	---	
2	2 1/4	1237-32-36	3.00	2.812	3.00	.375	2.44	1.94	.75	.62	2.260	2.500	228	2.1
		1238-32-36										---	---	
2	2 1/2	1237-32-40	3.00	2.812	3.00	.375	2.44	1.94	.75	.62	2.510	2.500	228	1.9
		1238-32-40										---	---	
2 1/2	3	1237-40-48	3.25	3.312	3.62	.375	2.89	2.32	.75	.62	3.010	3.000	232	2.9
		1238-40-48										---	---	

MATERIAL:
Low Carbon Steel

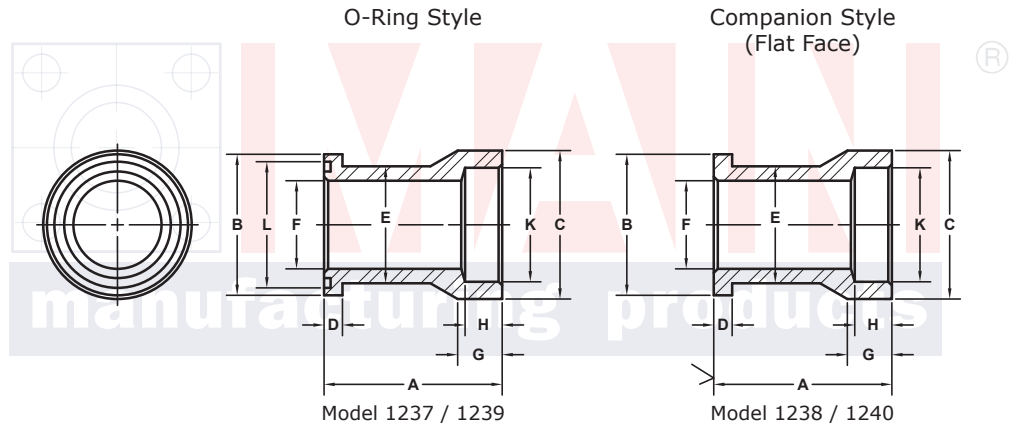
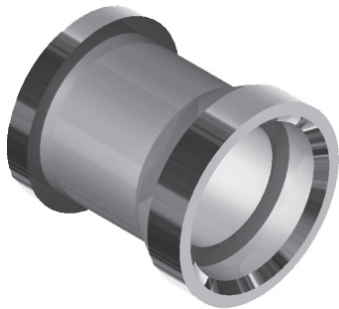

3181 TRI-PARK DR. GRAND BLANC, MI 48439 800-521-7918 810-953-1380 FAX 810-953-1385 INFO@MAINMFG.COM

62 SERIES

FLANGE SIZE	TUBE SIZE	PART NUMBER	A	B	C	D	E	F	G	H	K	L	O-RING NO. ①	WT
1/2	5/8	1239-08-10	2.38	1.250	1.31	.305	.92	.50	.62	.50	.635	1.000	210	.5
		1240-08-10										---	---	
1/2	3/4	1239-08-12	2.38	1.250	1.31	.305	.92	.50	.62	.50	.760	1.000	210	.5
		1240-08-12										---	---	
3/4	1	1239-12-16	2.75	1.625	1.62	.345	1.23	.69	.62	.50	1.010	1.250	214	.8
		1240-12-16										---	---	
1	1 1/4	1239-16-20	3.00	1.875	2.00	.375	1.48	.88	.62	.50	1.260	1.562	219	1.2
		1240-16-20										---	---	
1 1/4	1 1/2	1239-20-24	3.12	2.125	2.38	.405	1.69	1.19	.62	.50	1.510	1.750	222	1.5
		1240-20-24										---	---	
1 1/2	1 3/4	1239-24-28	3.75	2.500	2.75	.495	1.97	1.38	.62	.50	1.760	2.125	225	2.4
		1240-24-28										---	---	
1 1/2	2	1239-24-32	3.75	2.500	2.75	.495	1.97	1.38	.62	.50	2.010	2.125	225	2.3
		1240-24-32										---	---	
2	2 1/4	1239-32-36	4.00	3.125	3.50	.495	2.60	1.75	.75	.62	2.260	2.500	228	4.5
		1240-32-36										---	---	

① Order Separately