

BUTT WELD IN-LINE FLANGES (Pg 1/2)

For Schedule XXS Pipe ⑥

SAE BOLT PATTERN			61 SERIES												
FLANGE SIZE	PIPE SIZE	PART NUMBER	A	B	C	D	E	F	G	H	K	MOUNTING KIT®			WT
									J			PART NO.	SCREW SIZE	O-RING	
1/2	1/2	1121-08-08	1.50	2.12	1.25	1.500	.688	.25	.34	.38	.88	MK 512	5/16-18 x 1 1/2	210	.8
		1122-08-08							5/16-18						
3/4	1/2	1121-12-08	1.75	2.62	1.25	1.875	.875	.25	.41	.38	.88	MK 1525	3/8-16 x 1 1/2	214	1.1
		1122-12-08							3/8-16						
3/4	3/4	1121-12-12	1.75	2.62	1.25	1.875	.875	.44	.41	.38	1.12	MK 1525	3/8-16 x 1 1/2	214	1.1
		1122-12-12							3/8-16						
1	3/4	1121-16-12	2.00	2.82	1.38	2.062	1.031	.44	.41	.50	1.12	MK 1542	3/8-16 x 1 1/2	219	1.4
		1122-16-12							3/8-16						
1	1	1121-16-16	2.00	2.82	1.38	2.062	1.031	.60	.41	.50	1.38	MK 1542	3/8-16 x 1 1/2	219	1.4
		1122-16-16							3/8-16						
1 1/4	1	1121-20-16	2.50	3.19	1.38	2.312	1.188	.60	.47	.50	1.38	MK 1527	7/16-14 x 1 1/2	222	2.0
		1122-20-16							7/16-14						
1 1/4	1 1/4	1121-20-20	2.50	3.19	1.38	2.312	1.188	.89	.47	.50	1.75	MK 1527	7/16-14 x 1 1/2	222	1.9
		1122-20-20							7/16-14						
1 1/4	1 1/2	-----	2.50	3.19	1.50	2.312	1.188	1.10	----	.50	2.00	-----	-----	---	2.1
		1122-20-24							7/16-14						
1 1/2	1 1/4	1121-24-20	2.75	3.75	1.50	2.750	1.406	.89	.53	.50	1.75	MK 1547	1/2-13 x 1 3/4	225	2.8
		1122-24-20							1/2-13						
1 1/2	1 1/2	1121-24-24	2.75	3.75	1.50	2.750	1.406	1.10	.53	.50	2.00	MK 1547	1/2-13 x 1 3/4	225	2.7
		1122-24-24							1/2-13						
1 1/2	2	-----	3.50	3.75	2.50	2.750	1.406	1.50	----	.75	2.50	-----	-----	---	5.9
		1122-24-32							1/2-13						

MATERIAL:
Low Carbon Steel

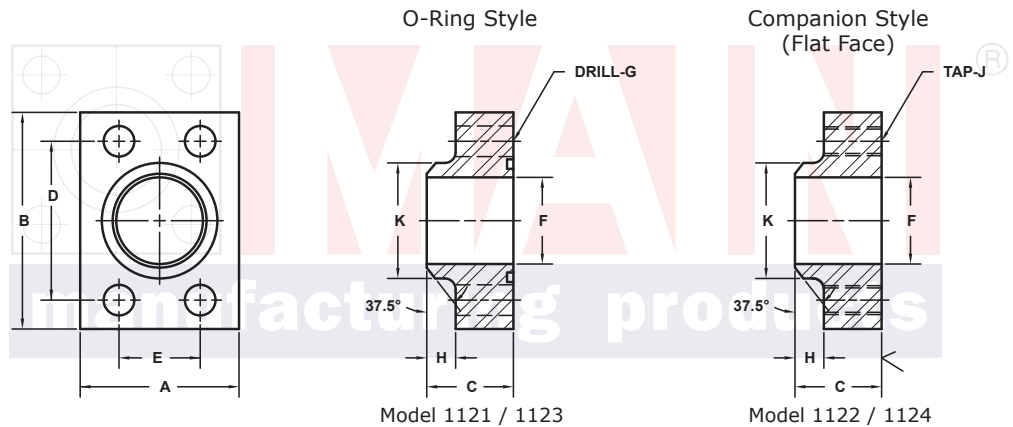

3181 TRI-PARK DR. GRAND BLANC, MI 48439 800-521-7918 810-953-1380 FAX 810-953-1385 INFO@MAINMFG.COM

SAE BOLT PATTERN			62 SERIES												
FLANGE SIZE	PIPE SIZE	PART NUMBER	A	B	C	D	E	F	G	H	K	MOUNTING KIT®			WT
									J			PART NO.	SCREW SIZE	O-RING	
1/2	1/2	1123-08-08	1.75	2.22	1.25	1.594	.718	.25	.34	.38	.88	MK 512	5/16-18 x 1 1/2	210	.9
		1124-08-08							5/16-18						
3/4	1/2	1123-12-08	2.00	2.81	1.25	2.000	.937	.25	.41	.38	.88	MK 1525	3/8-16 x 1 1/2	214	1.3
		1124-12-08							3/8-16						
3/4	3/4	1123-12-12	2.00	2.81	1.25	2.000	.937	.44	.41	.38	1.12	MK 1525	3/8-16 x 1 1/2	214	1.3
		1124-12-12							3/8-16						
1	3/4	1123-16-12	2.25	3.19	1.50	2.250	1.093	.44	.47	.50	1.12	MK 1504	7/16-14 x 2	219	2.0
		1124-16-12							7/16-14						
1	1	1123-16-16	2.25	3.19	1.50	2.250	1.093	.60	.47	.50	1.38	MK 1504	7/16-14 x 2	219	2.0
		1124-16-16							7/16-14						
1 1/4	1	1123-20-16	2.75	3.75	1.50	2.625	1.250	.60	.53	.50	1.38	MK 2540	1/2-13 x 1 3/4	222	2.8
		1124-20-16							1/2-13						
1 1/4	1 1/4	1123-20-20	2.75	3.75	1.50	2.625	1.250	.89	.53	.50	1.75	MK 2540	1/2-13 x 1 3/4	222	2.8
		1124-20-20							1/2-13						
1 1/4	1 1/2	-----	3.00	3.75	1.75	2.625	1.250	1.10	----	.75	2.00	-----	-----	---	3.1
		1124-20-24							1/2-13						

① Order Separately

⑥ Other Pipe and Tube Sizes are Available

BUTT WELD IN-LINE FLANGES (Pg 2/2)

For Schedule XXS Pipe ⑥

SAE BOLT PATTERN										61 SERIES					
FLANGE SIZE	PIPE SIZE	PART NUMBER	A	B	C	D	E	F	G J	H	K	MOUNTING KIT①			WT
												PART NO.	SCREW SIZE	O-RING	
2	1 1/4	1121-32-20	3.25	4.00	1.50	3.062	1.688	.89	.53	.50	1.75	MK 582	1/2-13 x 1 3/4	228	3.5
		1122-32-20							1/2-13						
2	1 1/2	1121-32-24	3.25	4.00	1.50	3.062	1.688	1.10	.53	.50	2.00	MK 582	1/2-13 x 1 3/4	228	3.5
		1122-32-24							1/2-13						
2	2	1121-32-32	3.25	4.00	1.75	3.062	1.688	1.50	.53	.75	2.50	MK 582	1/2-13 x 1 3/4	228	3.6
		1122-32-32							1/2-13						
2 1/2 ^②	2	1121-40-32	4.00	4.50	2.00	3.500	2.000	1.50	.53	.75	2.50	MK 561	1/2-13 x 2	232	6.1
		1122-40-32							1/2-13						
2 1/2 ^②	2 1/2	1121-40-40	4.00	4.50	2.00	3.500	2.000	1.77	.53	.75	3.00	MK 561	1/2-13 x 2	232	6.0
		1122-40-40							1/2-13						
3 ^③	2 1/2	1121-48-40	4.50	5.31	2.25	4.188	2.438	1.77	.66	.75	3.00	MK 585	5/8-11 x 2 1/2	237	9.5
		1122-48-40							5/8-11						
3 ^③	3	1121-48-48	4.50	5.31	2.25	4.188	2.438	2.30	.66	.75	3.50	MK 585	5/8-11 x 2 1/2	237	8.8
		1122-48-48							5/8-11						
3 1/2 ^④	3	1121-56-48	5.00	6.00	1.75	4.750	2.750	2.30	.66	.75	3.50	MK 1571	5/8-11 x 2	241	7.9
		1122-56-48							5/8-11						
3 1/2 ^④	3 1/2	1121-56-56	5.00	6.00	1.75	4.750	2.750	2.73	.66	.75	4.00	MK 1571	5/8-11 x 2	241	7.6
		1122-56-56							5/8-11						
4 ^④	3	1121-64-48	5.50	6.38	1.75	5.125	3.062	2.30	.66	.75	3.50	MK 1572	5/8-11 x 2	245	9.3
		1122-64-48							5/8-11						
4 ^④	4	1121-64-64	5.50	6.38	1.75	5.125	3.062	3.15	.66	.75	4.50	MK 1572	5/8-11 x 2	245	8.7
		1122-64-64							5/8-11						

MATERIAL:
Low Carbon Steel

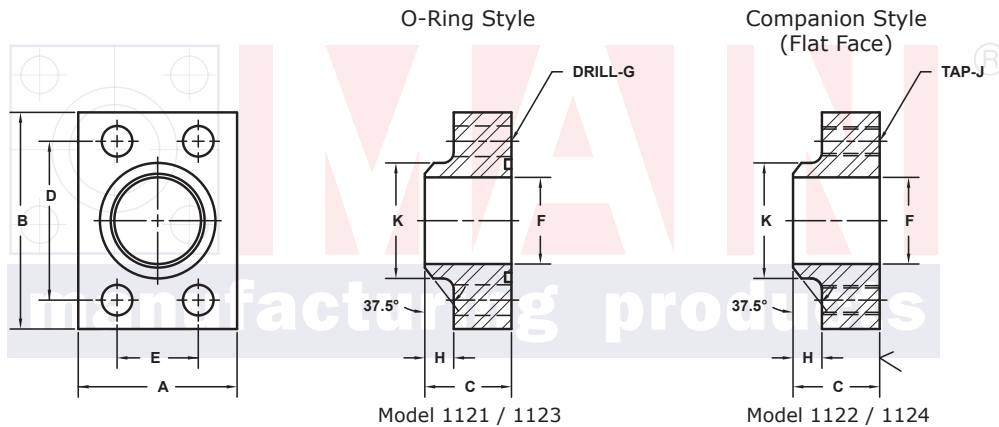

3181 TRI-PARK DR. GRAND BLANC, MI 48439 800-521-7918 810-953-1380 FAX 810-953-1385 INFO@MAINMFG.COM

SAE BOLT PATTERN										62 SERIES					
FLANGE SIZE	PIPE SIZE	PART NUMBER	A	B	C	D	E	F	G J	H	K	MOUNTING KIT①			WT
												PART NO.	SCREW SIZE	O-RING	
1 1/2	1 1/4	1123-24-20	3.25	4.50	1.50	3.125	1.437	.89	.66	.50	1.75	MK 562	5/8-11 x 2	225	3.9
		1124-24-20							5/8-11						
1 1/2	1 1/2	1123-24-24	3.25	4.50	1.50	3.125	1.437	1.10	.66	.50	2.00	MK 562	5/8-11 x 2	225	3.9
		1124-24-24							5/8-11						
1 1/2	2	-----	4.00	4.50	2.00	3.125	1.437	1.50	---	.75	2.50	-----	-----	---	6.0
		1124-24-32							5/8-11						
2	1 1/2	1123-32-24	4.00	5.25	1.75	3.812	1.750	1.10	.78	.50	2.00	MK 1548	3/4-10 x 2 1/2	228	6.9
		1124-32-24							3/4-10						
2	2	1123-32-32	4.00	5.25	2.00	3.812	1.750	1.50	.78	.75	2.50	MK 1548	3/4-10 x 2 1/2	228	6.9
		1124-32-32							3/4-10						
2 1/2	2	1123-40-32	5.00	6.88	2.50	4.875	2.312	1.50	.94	.75	2.50	MK 5535	7/8-9 x 3	232	15.8
		1124-40-32							7/8-9						
2 1/2	2 1/2	1123-40-40	5.00	6.88	2.50	4.875	2.312	1.77	.94	.75	3.00	MK 5535	7/8-9 x 3	232	15.7
		1124-40-40							7/8-9						
3	3	1123-48-48	6.00	8.50	3.00	6.000	2.812	2.30	1.19	.88	3.50	MK 1776	1 1/8-7 x 4	237	27.4
		1124-48-48							1 1/8-7						

① Order Separately ② 2500 PSI Max ③ 2000 PSI Max ④ 500 PSI Max
⑥ Other Pipe and Tube Sizes are Available