

BUTT WELD IN-LINE FLANGES (Pg 1/2)

For Schedule 40 Pipe ⑥

SAE J518 61 SERIES / ISO6162-1 PATTERN

FLANGE SIZE	PIPE SIZE	PART NUMBER	A	B	C	D	E	F	G		H	K	MOUNTING KIT®			WT
									Gmm	Jmm			PART NO.	SCREW SIZE	O-RING	
1/2	1/2	1105-08-08M8	1.50	2.12	1.25	1.500	.688	.62	8.5	M8x1.25	.38	.88	MKM 512	M8 x 35	210	.7
		-----							-----				---			
3/4	1/2	1105-12-08M10	1.75	2.62	1.25	1.875	.875	.62	10.5	M10x1.5	.38	.88	MKM 1525	M10 x 35	214	1.0
		-----							-----				---			
3/4	3/4	1105-12-12M10	1.75	2.62	1.25	1.875	.875	.82	10.5	M10x1.5	.38	1.12	MKM 1525	M10 x 35	214	1.0
		-----							-----				---			
1	3/4	1105-16-12M10	2.00	2.82	1.25	2.062	1.031	.82	10.5	M10x1.5	.38	1.12	MKM 1542	M10 x 35	219	1.3
		-----							-----				---			
1	1	1105-16-16M10	2.00	2.82	1.25	2.062	1.031	1.04	10.5	M10x1.5	.38	1.38	MKM 1542	M10 x 35	219	1.2
		-----							-----				---			
1 1/4	1	1105-20-16M10†	2.50	3.19	1.25	2.312	1.188	1.04	10.5	M10x1.5	.38	1.38	MKM 4520	M10 x 35	222	1.7
		-----							-----				---			
1 1/4	1 1/4	1105-20-20M10†	2.50	3.19	1.25	2.312	1.188	1.38	10.5	M10x1.5	.38	1.75	MKM 4520	M10 x 35	222	1.6
		-----							-----				---			
1 1/4	1 1/2	-----	2.50	3.19	1.50	2.312	1.188	1.61	-----	M10x1.5	.50	2.00	-----	-----	---	2.0
		1106-20-24M10†							-----				-----	---		
1 1/2	1 1/4	1105-24-20M12‡	2.75	3.75	1.50	2.750	1.406	1.38	13.0	M12x1.75	.50	1.75	MKM 4551	M12 x 40	225	2.6
		-----							-----				---			
1 1/2	1 1/2	1105-24-24M12‡	2.75	3.75	1.50	2.750	1.406	1.61	13.0	M12x1.75	.50	2.00	MKM 4551	M12 x 40	225	2.3
		-----							-----				---			
1 1/2	2	-----	3.50	3.75	2.25	2.750	1.406	2.06	-----	M12x1.75	.50	2.50	-----	-----	---	5.6
		1106-24-32M12‡							-----				-----	---		

MATERIAL:
Low Carbon Steel

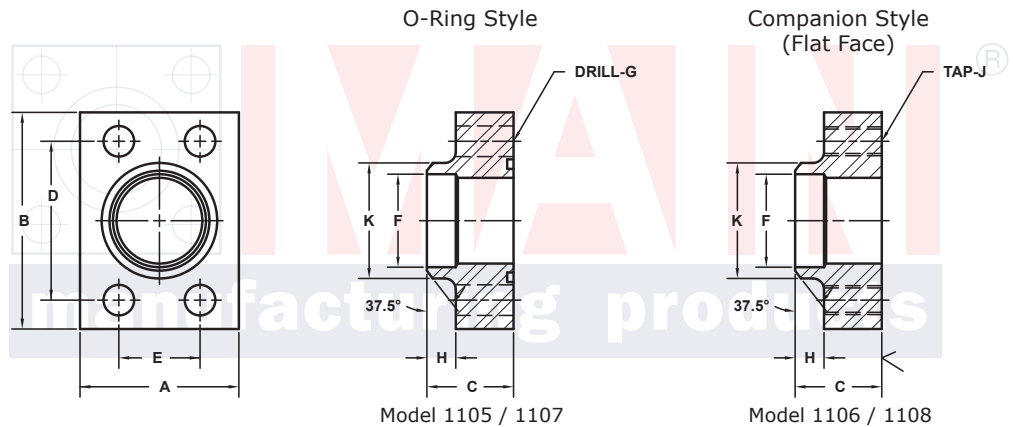

3181 TRI-PARK DR. GRAND BLANC, MI 48439 800-521-7918 810-953-1380 FAX 810-953-1385 INFO@MAINMFG.COM

SAE J518 62 SERIES / ISO6162-2 PATTERN

FLANGE SIZE	PIPE SIZE	PART NUMBER	A	B	C	D	E	F	G		H	K	MOUNTING KIT®			WT
									Gmm	Jmm			PART NO.	SCREW SIZE	O-RING	
1/2	1/2	1107-08-08M8	1.75	2.22	1.25	1.594	.718	.62	8.5	M8x1.25	.38	.88	MKM 512	M8 x 35	210	.8
		-----							-----				---			
3/4	1/2	1107-12-08M10	2.00	2.81	1.25	2.000	.937	.62	10.5	M10x1.5	.38	.88	MKM 1525	M10 x 35	214	1.3
		-----							-----				---			
3/4	3/4	1107-12-12M10	2.00	2.81	1.25	2.000	.937	.82	10.5	M10x1.5	.38	1.12	MKM 1525	M10 x 35	214	1.3
		-----							-----				---			
1	3/4	1107-16-12M12	2.25	3.19	1.25	2.250	1.093	.82	12.5	M12x1.75	.38	1.12	MKM 4569	M12 x 40	219	1.6
		-----							-----				---			
1	1	1107-16-16M12	2.25	3.19	1.25	2.250	1.093	1.04	12.5	M12x1.75	.38	1.38	MKM 4569	M12 x 40	219	1.5
		-----							-----				---			
1 1/4	1	1107-20-16M12‡	2.75	3.75	1.25	2.625	1.250	1.04	13.0	M12x1.75	.38	1.38	MKM 1527	M12 x 40	222	2.3
		-----							-----				---			
1 1/4	1 1/4	1107-20-20M12‡	2.75	3.75	1.25	2.625	1.250	1.38	13.0	M12x1.75	.38	1.75	MKM 1527	M12 x 40	222	2.1
		-----							-----				---			
1 1/4	1 1/2	-----	3.00	3.75	1.50	2.625	1.250	1.61	-----	M12x1.75	.50	2.00	-----	-----	---	3.1
		1108-20-24M12‡							-----				-----	---		

① Order Separately

⑥ Other Pipe and Tube Sizes are Available

34 NOTE: DIMENSIONS ARE IN INCHES UNLESS OTHERWISE NOTED. † Also Available for M12 Bolts ‡ Also Available for M14 Bolts

© Copyright MAIN Mfg. 2017

BUTT WELD IN-LINE FLANGES (Pg 2/2)

For Schedule 40 Pipe ©

SAE J518 61 SERIES / ISO6162-1 PATTERN

FLANGE SIZE	PIPE SIZE	PART NUMBER	A	B	C	D	E	F	Gmm		H	K	MOUNTING KIT®			WT
									Jmm				PART NO.	SCREW SIZE	O-RING	
2	1 1/4	1105-32-20M12+	3.25	4.00	1.50	3.062	1.688	1.38	13.0	.50	1.75	M12 x 45	M12 x 45	228	3.3	
		M12x1.75							-----							---
2	1 1/2	1105-32-24M12+	3.25	4.00	1.50	3.062	1.688	1.61	13.0	.50	2.00	M12 x 45	M12 x 45	228	3.2	
		M12x1.75							-----							---
2	2	1105-32-32M12+	3.25	4.00	1.50	3.062	1.688	2.06	13.0	.50	2.50	M12 x 45	M12 x 45	228	2.8	
		M12x1.75							-----							---
2 1/2 ^②	2	1105-40-32M12+	4.00	4.50	1.75	3.500	2.000	2.06	13.0	.50	2.50	M12 x 50	M12 x 50	232	5.3	
		M12x1.75							-----							---
2 1/2 ^②	2 1/2	1105-40-40M12+	4.00	4.50	1.75	3.500	2.000	2.47	13.0	.50	3.00	M12 x 50	M12 x 50	232	4.8	
		M12x1.75							-----							---
3 ^③	2 1/2	1105-48-40M16	4.50	5.31	2.00	4.188	2.438	2.47	17.0	.50	3.00	M16 x 60	M16 x 60	237	8.1	
		M16x2							-----							---
3 ^③	3	1105-48-48M16	4.50	5.31	2.00	4.188	2.438	3.06	17.0	.50	3.50	M16 x 60	M16 x 60	237	7.2	
		M16x2							-----							---
3 1/2 ^④	3	1105-56-48M16	5.00	6.00	1.50	4.750	2.750	3.06	17.0	.50	3.50	M16 x 50	M16 x 50	241	6.6	
		M16x2							-----							---
3 1/2 ^④	3 1/2	1105-56-56M16	5.00	6.00	1.50	4.750	2.750	3.54	17.0	.50	4.00	M16 x 50	M16 x 50	241	5.9	
		M16x2							-----							---
4 ^④	3	1105-64-48M16	5.50	6.38	1.50	5.125	3.062	3.06	17.0	.50	3.50	M16 x 50	M16 x 50	245	8.1	
		M16x2							-----							---
4 ^④	4	1105-64-64M16	5.50	6.38	1.50	5.125	3.062	4.02	17.0	.50	4.50	M16 x 50	M16 x 50	245	6.7	
		M16x2							-----							---

MATERIAL:
Low Carbon Steel

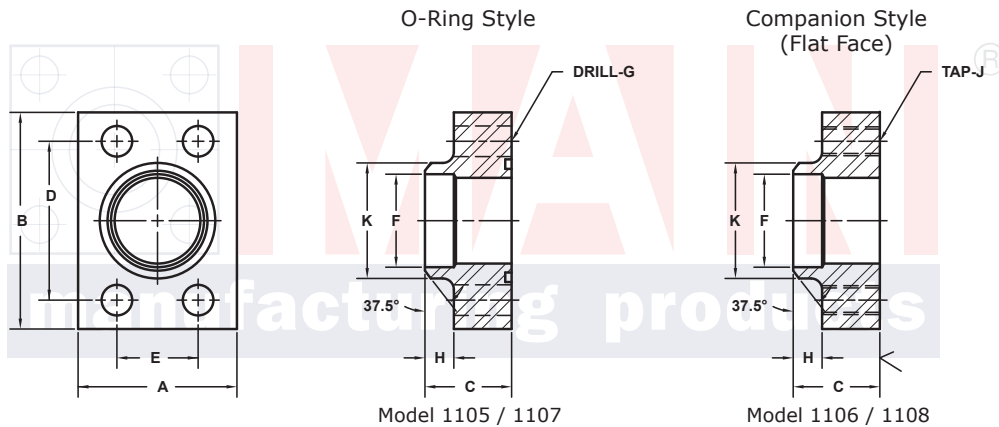

3181 TRI-PARK DR. GRAND BLANC, MI 48439 800-521-7918 810-953-1380 FAX 810-953-1385 INFO@MAINMFG.COM

SAE J518 62 SERIES / ISO6162-2 PATTERN

FLANGE SIZE	PIPE SIZE	PART NUMBER	A	B	C	D	E	F	Gmm		H	K	MOUNTING KIT®			WT
									Jmm				PART NO.	SCREW SIZE	O-RING	
1 1/2	1 1/4	1107-24-20M16	3.25	4.50	1.50	3.125	1.437	1.38	17.0	.50	1.75	M16 x 45	M16 x 45	225	3.5	
		M16x2							-----							---
1 1/2	1 1/2	1107-24-24M16	3.25	4.50	1.50	3.125	1.437	1.61	17.0	.50	2.00	M16 x 45	M16 x 45	225	3.3	
		M16x2							-----							---
1 1/2	2	-----	4.00	4.50	2.00	3.125	1.437	2.06	-----	.50	2.50	-----	-----	---	6.8	
		M16x2							-----			---				
2	1 1/2	1107-32-24M20	4.00	5.25	1.75	3.812	1.750	1.61	21.0	.50	2.00	M20 x 60	M20 x 60	228	6.4	
		M20x2.5							-----							---
2	2	1107-32-32M20	4.00	5.25	1.75	3.812	1.750	2.06	21.0	.50	2.50	M20 x 60	M20 x 60	228	5.9	
		M20x2.5							-----							---
2 1/2	2	1107-40-32M24	5.00	6.88	2.00	4.875	2.312	2.06	25.5	.50	2.50	M24 x 70	M24 x 70	232	12.8	
		M24x3							-----							---
2 1/2	2 1/2	1107-40-40M24	5.00	6.88	2.00	4.875	2.312	2.47	25.5	.50	3.00	M24 x 70	M24 x 70	232	12.0	
		M24x3							-----							---
3	3	1107-48-48M30	6.00	8.50	2.50	6.000	2.812	3.06	32.0	.50	3.50	M30 x 100	M30 x 100	237	23.3	
		M30x3.5							-----							---

① Order Separately ② 2500 PSI Max ③ 2000 PSI Max ④ 500 PSI Max

® Other Pipe and Tube Sizes are Available

NOTE: DIMENSIONS ARE IN INCHES UNLESS OTHERWISE NOTED. + Also Available for M12 Bolts † Also Available for M14 Bolts

© Copyright MAIN Mfg. 2017