

BUTT WELD ELBOW FLANGES (Pg 1/2)

For Schedule 40 Pipe ©

SAE J518 61 SERIES / ISO6162-1 PATTERN

FLANGE SIZE	PIPE SIZE	PART NUMBER	A	B	C	D	E	F	Gmm	H	K	MOUNTING KIT®			WT
									Jmm			PART NO.	SCREW SIZE	O-RING	
1/2	1/2	1133-08-08M8	2.00	2.12	1.44	1.500	.688	.62	8.5	.75	.88	MKM 541	M8 x 50	210	1.3
		M8x1.25							-----			---			
3/4	1/2	1133-12-08M10	2.25	2.62	1.70	1.875	.875	.62	10.5	.88	.88	MKM 542	M10 x 60	214	2.1
		M10x1.5							-----			---			
3/4	3/4	1133-12-12M10	2.25	2.62	1.70	1.875	.875	.82	10.5	.88	1.12	MKM 542	M10 x 60	214	2.1
		M10x1.5							-----			---			
1	3/4	1133-16-12M10	2.50	2.82	1.94	2.062	1.031	.82	10.5	1.00	1.12	MKM 543	M10 x 65	219	2.8
		M10x1.5							-----			---			
1	1	1133-16-16M10	2.50	2.82	1.94	2.062	1.031	1.04	10.5	1.00	1.38	MKM 543	M10 x 65	219	2.8
		M10x1.5							-----			---			
1 1/4	1	1133-20-16M10†	3.00	3.19	2.40	2.312	1.188	1.04	10.5	1.25	1.38	MKM 4532	M10 x 75	222	4.8
		M10x1.5							-----			---			
1 1/4	1 1/4	1133-20-20M10†	3.00	3.19	2.40	2.312	1.188	1.38	10.5	1.25	1.75	MKM 4532	M10 x 75	222	4.7
		M10x1.5							-----			---			
1 1/4	1 1/2	1133-20-24M10†	3.00	3.19	3.00	2.312	1.188	1.61	10.5	1.25	2.00	MKM 4597	M10 x 90	222	5.7
		M10x1.5							-----			---			
1 1/2	1 1/4	1133-24-20M12‡	3.25	3.75	2.90	2.750	1.406	1.38	13.0	1.38	1.75	MKM 4533	M12 x 90	225	6.8
		M12x1.75							-----			---			
1 1/2	1 1/2	1133-24-24M12‡	3.25	3.75	2.90	2.750	1.406	1.61	13.0	1.38	2.00	MKM 4533	M12 x 90	225	6.7
		M12x1.75							-----			---			
1 1/2	2	1133-24-32M12‡	3.50	3.75	3.50	2.750	1.406	2.06	13.0	1.38	2.50	MKM 3521	M12 x 100	225	9.1
		M12x1.75							-----			---			

MATERIAL:

Low Carbon Steel

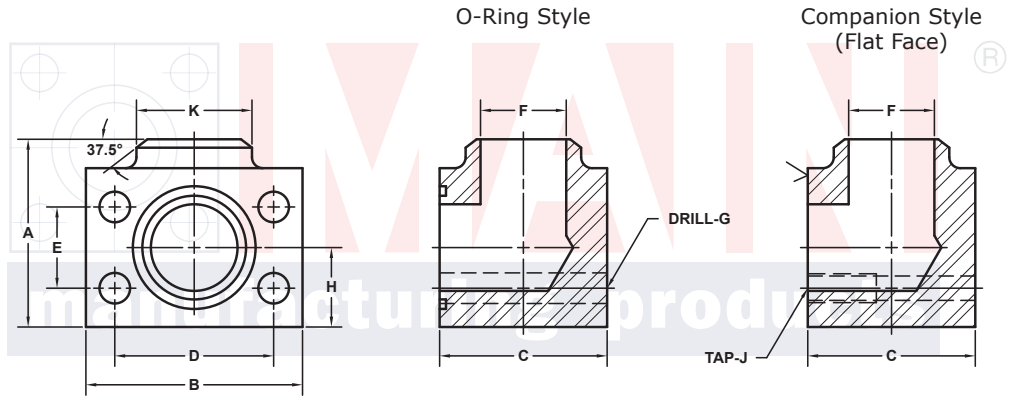
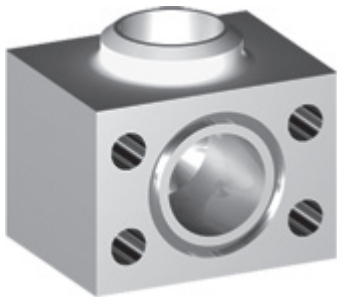

Model 1133 / 1135

Model 1134 / 1136

3181 TRI-PARK DR. GRAND BLANC, MI 48439 800-521-7918 810-953-1380 FAX 810-953-1385 INFO@MAINMFG.COM

SAE J518 62 SERIES / ISO6162-2 PATTERN

FLANGE SIZE	PIPE SIZE	PART NUMBER	A	B	C	D	E	F	Gmm	H	K	MOUNTING KIT®			WT
									Jmm			PART NO.	SCREW SIZE	O-RING	
1/2	1/2	1135-08-08M8	2.25	2.22	1.46	1.594	.718	.62	8.5	.88	.88	MKM 541	M8 x 50	210	1.5
		M8x1.25							-----			---			
3/4	1/2	1135-12-08M10	2.50	2.81	1.70	2.000	.937	.62	10.5	1.00	.88	MKM 542	M10 x 60	214	2.6
		M10x1.5							-----			---			
3/4	3/4	1135-12-12M10	2.50	2.81	1.70	2.000	.937	.82	10.5	1.00	1.12	MKM 542	M10 x 60	214	2.5
		M10x1.5							-----			---			
1	3/4	1135-16-12M12	2.75	3.19	2.21	2.250	1.093	.82	12.5	1.12	1.12	MKM 2533	M12 x 75	219	4.1
		M12x1.75							-----			---			
1	1	1135-16-16M12	2.75	3.19	2.21	2.250	1.093	1.04	12.5	1.12	1.38	MKM 2533	M12 x 75	219	4.0
		M12x1.75							-----			---			
1 1/4	1	1135-20-16M12‡	3.25	3.75	2.44	2.625	1.250	1.04	13.0	1.38	1.38	MKM 578	M12 x 80	222	6.3
		M12x1.75							-----			---			
1 1/4	1 1/4	1135-20-20M12‡	3.25	3.75	2.44	2.625	1.250	1.38	13.0	1.38	1.75	MKM 578	M12 x 80	222	6.1
		M12x1.75							-----			---			

① Order Separately

® Schedules 80, 160 and XXS also Stocked. Other Pipe and Tube Sizes are Available

42 NOTE: DIMENSIONS ARE IN INCHES UNLESS OTHERWISE NOTED. † Also Available for M12 Bolts ‡ Also Available for M14 Bolts

© Copyright MAIN Mfg. 2017

BUTT WELD ELBOW FLANGES (Pg 2/2)

For Schedule 40 Pipe ©

SAE J518 61 SERIES / ISO6162-1 PATTERN

FLANGE SIZE	PIPE SIZE	PART NUMBER	A	B	C	D	E	F	Gmm Jmm	H	K	MOUNTING KIT®			WT
												PART NO.	SCREW SIZE	O-RING	
2	1¼	1133-32-20M12†	3.75	4.00	3.40	3.062	1.688	1.38	13.0	1.62	1.75	MKM 4534	M12 x 100	228	9.9
		M12x1.75							-----			---			
2	1½	1133-32-24M12†	3.75	4.00	3.40	3.062	1.688	1.61	13.0	1.62	2.00	MKM 4534	M12 x 100	228	9.7
		M12x1.75							-----			---			
2	2	1133-32-32M12†	3.75	4.00	3.40	3.062	1.688	2.06	13.0	1.62	2.50	MKM 4534	M12 x 100	228	9.2
		M12x1.75							-----			---			
2½ ^②	2	1133-40-32M12†	4.50	4.50	3.96	3.500	2.000	2.06	13.0	2.00	2.50	MKM 4535	M12 x 120	232	15.1
		M12x1.75							-----			---			
2½ ^②	2½	1133-40-40M12†	4.50	4.50	3.96	3.500	2.000	2.47	13.0	2.00	3.00	MKM 4535	M12 x 120	232	14.5
		M12x1.75							-----			---			
3 ^③	2½	1133-48-40M16	5.00	5.31	4.96	4.188	2.438	2.47	17.0	2.25	3.00	MKM 548	M16 x 150	237	24.6
		M16x2							-----			---			
3 ^③	3	1133-48-48M16	5.00	5.31	4.96	4.188	2.438	3.06	17.0	2.25	3.50	MKM 548	M16 x 150	237	23.1
		M16x2							-----			---			
3½ ^④	3	1133-56-48M16	5.50	6.00	5.40	4.750	2.750	3.06	17.0	2.50	3.50	MKM 549	M16 x 160	241	32.2
		M16x2							-----			---			
3½ ^④	3½	1133-56-56M16	5.50	6.00	5.40	4.750	2.750	3.54	17.0	2.50	4.00	MKM 549	M16 x 160	241	30.7
		M16x2							-----			---			
4 ^④	3	1133-64-48M16	6.00	6.38	5.96	5.125	3.062	3.06	17.0	2.75	3.50	MKM 550	M16 x 180	245	41.4
		M16x2							-----			---			
4 ^④	4	1133-64-64M16	6.00	6.38	5.96	5.125	3.062	4.02	17.0	2.75	4.50	MKM 550	M16 x 180	245	38.0
		M16x2							-----			---			

MATERIAL:
Low Carbon Steel

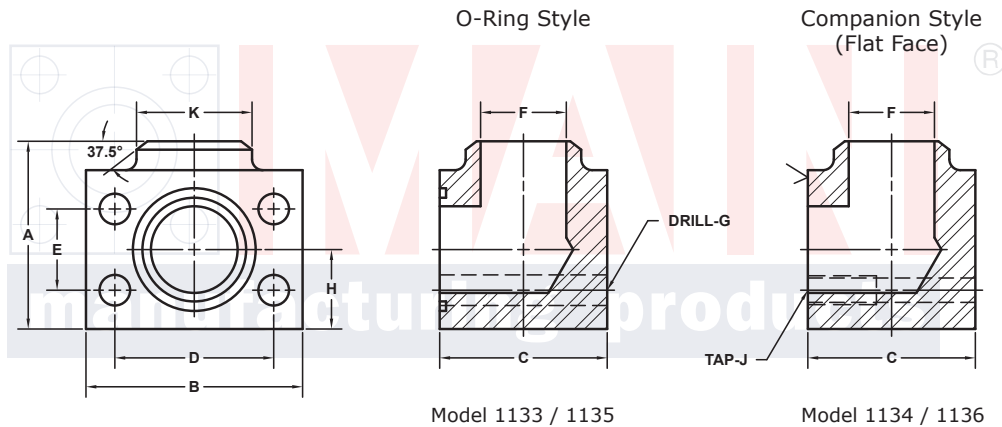

3181 TRI-PARK DR. GRAND BLANC, MI 48439 800-521-7918 810-953-1380 FAX 810-953-1385 INFO@MAINMFG.COM

SAE J518 62 SERIES / ISO6162-2 PATTERN

FLANGE SIZE	PIPE SIZE	PART NUMBER	A	B	C	D	E	F	Gmm Jmm	H	K	MOUNTING KIT®			WT
												PART NO.	SCREW SIZE	O-RING	
1½	1¼	1135-24-20M16	3.75	4.50	2.96	3.125	1.437	1.38	17.0	1.62	1.75	MKM 553	M16 x 100	225	10.6
		M16x2							-----			---			
1½	1½	1135-24-24M16	3.75	4.50	2.96	3.125	1.437	1.61	17.0	1.62	2.00	MKM 553	M16 x 100	225	10.0
		M16x2							-----			---			
2	1½	1135-32-24M20	4.50	5.25	3.46	3.812	1.750	1.61	21.0	2.00	2.00	MKM 554	3/4-10 x 120	228	16.8
		M20x2.5							-----			---			
2	2	1135-32-32M20	4.50	5.25	3.46	3.812	1.750	2.06	21.0	2.00	2.50	MKM 554	3/4-10 x 120	228	16.2
		M20x2.5							-----			---			
2½	2	1135-40-32M24	5.50	6.88	4.50	4.875	2.312	2.06	25.5	2.50	2.50	MKM 2557	M24 x 150	232	36.3
		M24x3							-----			---			
2½	2½	1135-40-40M24	5.50	6.88	4.50	4.875	2.312	2.47	25.5	2.50	3.00	MKM 2557	M24 x 150	232	35.4
		M24x3							-----			---			
3	3	1135-48-48M30	6.50	8.50	5.00	6.000	2.812	3.06	32.0	3.00	3.50	MKM 556	M30 x 180	237	57.2
		M30x3.5							-----			---			

① Order Separately ② 2500 PSI Max ③ 2000 PSI Max ④ 500 PSI Max
 ® Schedules 80, 160 and XXS also Stocked. Other Pipe and Tube Sizes are Available

NOTE: DIMENSIONS ARE IN INCHES UNLESS OTHERWISE NOTED. † Also Available for M12 Bolts ‡ Also Available for M14 Bolts

© Copyright MAIN Mfg. 2017