

BUTT WELD ELBOW FLANGES (Pg 1/2)

For Schedule 40 Pipe ®

SAE BOLT PATTERN			61 SERIES												
FLANGE SIZE	PIPE SIZE	PART NUMBER	A	B	C	D	E	F	G	H	K	MOUNTING KIT®			WT
									J			PART NO.	SCREW SIZE	O-RING	
1/2	1/2	1133-08-08	2.00	2.12	1.44	1.500	.688	.62	.34	.75	.88	MK 541	5/16-18 x 2	210	1.3
		1134-08-08							5/16-18						
3/4	1/2	1133-12-08	2.25	2.62	1.70	1.875	.875	.62	.41	.88	.88	MK 542	3/8-16 x 2 1/2	214	2.1
		1134-12-08							3/8-16						
3/4	3/4	1133-12-12	2.25	2.62	1.70	1.875	.875	.82	.41	.88	1.12	MK 542	3/8-16 x 2 1/2	214	2.1
		1134-12-12							3/8-16						
1	3/4	1133-16-12	2.50	2.82	1.94	2.062	1.031	.82	.41	1.00	1.12	MK 543	3/8-16 x 2 3/4	219	2.8
		1134-16-12							3/8-16						
1	1	1133-16-16	2.50	2.82	1.94	2.062	1.031	1.04	.41	1.00	1.38	MK 543	3/8-16 x 2 3/4	219	2.8
		1134-16-16							3/8-16						
1 1/4	1	1133-20-16	3.00	3.19	2.40	2.312	1.188	1.04	.47	1.25	1.38	MK 578	7/16-14 x 3 1/4	222	4.8
		1134-20-16							7/16-14						
1 1/4	1 1/4	1133-20-20	3.00	3.19	2.40	2.312	1.188	1.38	.47	1.25	1.75	MK 578	7/16-14 x 3 1/4	222	4.7
		1134-20-20							7/16-14						
1 1/4	1 1/2	1133-20-24	3.00	3.19	3.00	2.312	1.188	1.61	.47	1.25	2.00	MK 591	7/16-14 x 4	222	5.7
		1134-20-24							7/16-14						
1 1/2	1 1/4	1133-24-20	3.25	3.75	2.90	2.750	1.406	1.38	.53	1.38	1.75	MK 545	1/2-13 x 4	225	6.8
		1134-24-20							1/2-13						
1 1/2	1 1/2	1133-24-24	3.25	3.75	2.90	2.750	1.406	1.61	.53	1.38	2.00	MK 545	1/2-13 x 4	225	6.7
		1134-24-24							1/2-13						
1 1/2	2	1133-24-32	3.50	3.75	3.50	2.750	1.406	2.06	.53	1.38	2.50	MK 579	1/2-13 x 4 1/2	225	9.1
		1134-24-32							1/2-13						

MATERIAL:
Low Carbon Steel

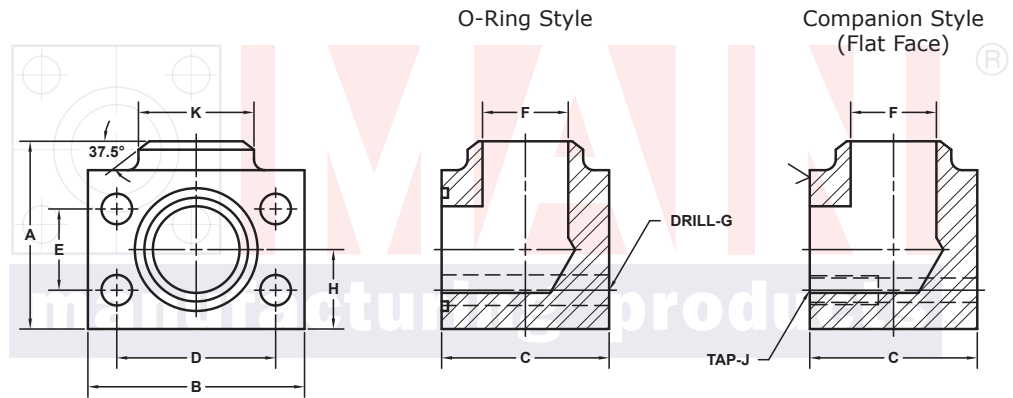
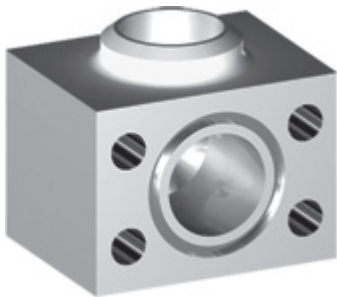

Model 1133 / 1135

Model 1134 / 1136

3181 TRI-PARK DR. GRAND BLANC, MI 48439 800-521-7918 810-953-1380 FAX 810-953-1385 INFO@MAINMFG.COM

SAE BOLT PATTERN			62 SERIES												
FLANGE SIZE	PIPE SIZE	PART NUMBER	A	B	C	D	E	F	G	H	K	MOUNTING KIT®			WT
									J			PART NO.	SCREW SIZE	O-RING	
1/2	1/2	1135-08-08	2.25	2.22	1.46	1.594	.718	.62	.34	.88	.88	MK 541	5/16-18 x 2	210	1.5
		1136-08-08							5/16-18						
3/4	1/2	1135-12-08	2.50	2.81	1.70	2.000	.937	.62	.41	1.00	.88	MK 542	3/8-16 x 2 1/2	214	2.6
		1136-12-08							3/8-16						
3/4	3/4	1135-12-12	2.50	2.81	1.70	2.000	.937	.82	.41	1.00	1.12	MK 542	3/8-16 x 2 1/2	214	2.5
		1136-12-12							3/8-16						
1	3/4	1135-16-12	2.75	3.19	2.21	2.250	1.093	.82	.47	1.12	1.12	MK 2533	7/16-14 x 3	219	4.1
		1136-16-12							7/16-14						
1	1	1135-16-16	2.75	3.19	2.21	2.250	1.093	1.04	.47	1.12	1.38	MK 2533	7/16-14 x 3	219	4.0
		1136-16-16							7/16-14						
1 1/4	1	1135-20-16	3.25	3.75	2.44	2.625	1.250	1.04	.53	1.38	1.38	MK 552	1/2-13 x 3 1/4	222	6.3
		1136-20-16							1/2-13						
1 1/4	1 1/4	1135-20-20	3.25	3.75	2.44	2.625	1.250	1.38	.53	1.38	1.75	MK 552	1/2-13 x 3 1/4	222	6.1
		1136-20-20							1/2-13						

① Order Separately

® Schedules 80, 160 and XXS also Stocked. Other Pipe and Tube Sizes are Available

BUTT WELD ELBOW FLANGES (Pg 2/2)

For Schedule 40 Pipe ©

SAE BOLT PATTERN										61 SERIES					
FLANGE SIZE	PIPE SIZE	PART NUMBER	A	B	C	D	E	F	G J	H	K	MOUNTING KIT®			WT
												PART NO.	SCREW SIZE	O-RING	
2	1 1/4	1133-32-20	3.75	4.00	3.40	3.062	1.688	1.38	.53	1.62	1.75	MK 546	1/2-13 x 4 1/2	228	9.9
		1134-32-20							1/2-13						
2	1 1/2	1133-32-24	3.75	4.00	3.40	3.062	1.688	1.61	.53	1.62	2.00	MK 546	1/2-13 x 4 1/2	228	9.7
		1134-32-24							1/2-13						
2	2	1133-32-32	3.75	4.00	3.40	3.062	1.688	2.06	.53	1.62	2.50	MK 546	1/2-13 x 4 1/2	228	9.2
		1134-32-32							1/2-13						
2 1/2 ^②	2	1133-40-32	4.50	4.50	3.96	3.500	2.000	2.06	.53	2.00	2.50	MK 547	1/2-13 x 5	232	15.1
		1134-40-32							1/2-13						
2 1/2 ^②	2 1/2	1133-40-40	4.50	4.50	3.96	3.500	2.000	2.47	.53	2.00	3.00	MK 547	1/2-13 x 5	232	14.5
		1134-40-40							1/2-13						
3 ^③	2 1/2	1133-48-40	5.00	5.31	4.96	4.188	2.438	2.47	.66	2.25	3.00	MK 548	5/8-11 x 6	237	24.6
		1134-48-40							5/8-11						
3 ^③	3	1133-48-48	5.00	5.31	4.96	4.188	2.438	3.06	.66	2.25	3.50	MK 548	5/8-11 x 6	237	23.1
		1134-48-48							5/8-11						
3 1/2 ^④	3	1133-56-48	5.50	6.00	5.40	4.750	2.750	3.06	.66	2.50	3.50	MK 549	5/8-11 x 6 1/2	241	32.2
		1134-56-48							5/8-11						
3 1/2 ^④	3 1/2	1133-56-56	5.50	6.00	5.40	4.750	2.750	3.54	.66	2.50	4.00	MK 549	5/8-11 x 6 1/2	241	30.7
		1134-56-56							5/8-11						
4 ^④	3	1133-64-48	6.00	6.38	5.96	5.125	3.062	3.06	.66	2.75	3.50	MK 550	5/8-11 x 7	245	41.4
		1134-64-48							5/8-11						
4 ^④	4	1133-64-64	6.00	6.38	5.96	5.125	3.062	4.02	.66	2.75	4.50	MK 550	5/8-11 x 7	245	38.0
		1134-64-64							5/8-11						

MATERIAL:
Low Carbon Steel

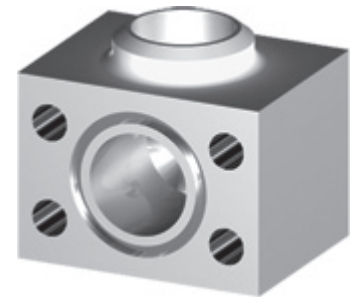
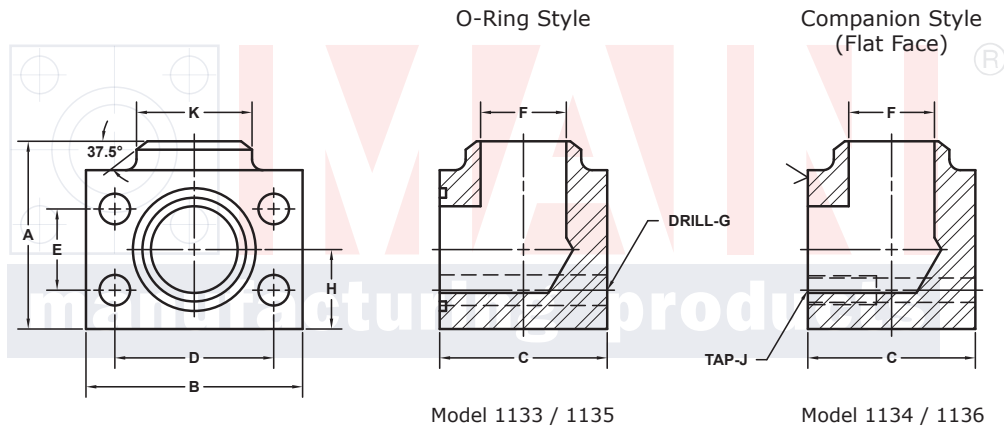

3181 TRI-PARK DR. GRAND BLANC, MI 48439 800-521-7918 810-953-1380 FAX 810-953-1385 INFO@MAINMFG.COM

SAE BOLT PATTERN										62 SERIES					
FLANGE SIZE	PIPE SIZE	PART NUMBER	A	B	C	D	E	F	G J	H	K	MOUNTING KIT®			WT
												PART NO.	SCREW SIZE	O-RING	
1 1/2	1 1/4	1135-24-20	3.75	4.50	2.96	3.125	1.437	1.38	.66	1.62	1.75	MK 553	5/8-11 x 4	225	10.6
		1136-24-20							5/8-11						
1 1/2	1 1/2	1135-24-24	3.75	4.50	2.96	3.125	1.437	1.61	.66	1.62	2.00	MK 553	5/8-11 x 4	225	10.0
		1136-24-24							5/8-11						
2	1 1/2	1135-32-24	4.50	5.25	3.46	3.812	1.750	1.61	.78	2.00	2.00	MK 554	3/4-10 x 4 1/2	228	16.8
		1136-32-24							3/4-10						
2	2	1135-32-32	4.50	5.25	3.46	3.812	1.750	2.06	.78	2.00	2.50	MK 554	3/4-10 x 4 1/2	228	16.2
		1136-32-32							3/4-10						
2 1/2	2	1135-40-32	5.50	6.88	4.50	4.875	2.312	2.06	.94	2.50	2.50	MK 2557	7/8-9 x 6	232	36.3
		1136-40-32							7/8-9						
2 1/2	2 1/2	1135-40-40	5.50	6.88	4.50	4.875	2.312	2.47	.94	2.50	3.00	MK 2557	7/8-9 x 6	232	35.4
		1136-40-40							7/8-9						
3	3	1135-48-48	6.50	8.50	5.00	6.000	2.812	3.06	1.19	3.00	3.50	MK 756	1 1/8-7 x 7	237	57.2
		1136-48-48							1 1/8-7						

① Order Separately ② 2500 PSI Max ③ 2000 PSI Max ④ 500 PSI Max
 © Schedules 80, 160 and XXS also Stocked. Other Pipe and Tube Sizes are Available