

# BSPP THREADED ELBOW FLANGES

## SAE J518 61 SERIES / ISO6162-1 PATTERN

FLANGE SIZE	PORT SIZE	PART NUMBER	A	B	C	D	E	F	Gmm Jmm	H	K	MOUNTING KIT <sup>①</sup>			WT
												PART NO.	SCREW SIZE	O-RING	
1/2	-8	1359-08-08M8	2.00	2.12	1.44	1.500	.688	.50	8.5	.75	1/2-14	MKM 541	M8 x 50	210	1.5
		1360-08-08M8							M8x1.25			---	---		
3/4	-8	1359-12-08M10	2.50	2.62	1.70	1.875	.875	.50	10.5	.88	1/2-14	MKM 542	M10 x 60	214	2.7
		1360-12-08M10							M10x1.5			---	---		
3/4	-12	1359-12-12M10	2.50	2.62	1.70	1.875	.875	.75	10.5	.88	3/4-14	MKM 542	M10 x 60	214	2.5
		1360-12-12M10							M10x1.5			---	---		
1	-12	1359-16-12M10	3.00	2.82	1.94	2.062	1.031	.75	10.5	1.00	3/4-14	MKM 543	M10 x 65	219	3.9
		1360-16-12M10							M10x1.5			---	---		
1	-16	1359-16-16M10	3.00	2.82	1.94	2.062	1.031	1.00	10.5	1.00	1-11	MKM 543	M10 x 65	219	3.7
		1360-16-16M10							M10x1.5			---	---		
1 1/4	-20	1359-20-20M10 <sup>+</sup>	3.50	3.19	2.40	2.312	1.188	1.25	10.5	1.25	1 1/4-11	MKM 4532	M10 x 75	222	5.8
		1360-20-20M10 <sup>+</sup>							M10x1.5			---	---		
1 1/2	-20	1359-24-20M12 <sup>+</sup>	4.00	3.75	2.90	2.750	1.406	1.50	13.0	1.38	1 1/4-11	MKM 4533	M12 x 90	225	9.2
		1360-24-20M12 <sup>+</sup>							M12x1.75			---	---		
1 1/2	-24	1359-24-24M12 <sup>+</sup>	4.00	3.75	2.90	2.750	1.406	1.50	13.0	1.38	1 1/2-11	MKM 4533	M12 x 90	225	9.2
		1360-24-24M12 <sup>+</sup>							M12x1.75			---	---		
2	-20	1359-32-20M12 <sup>+</sup>	4.50	4.00	2.96	3.062	1.688	1.94	13.0	1.62	1 1/4-11	MKM 4547	M12 x 90	228	12.0
		1360-32-20M12 <sup>+</sup>							M12x1.75			---	---		
2	-24	1359-32-24M12 <sup>+</sup>	4.50	4.00	2.96	3.062	1.688	1.94	13.0	1.62	1 1/2-11	MKM 4547	M12 x 90	228	12.0
		1360-32-24M12 <sup>+</sup>							M12x1.75			---	---		
2	-32	1359-32-32M12 <sup>+</sup>	4.50	4.00	3.40	3.062	1.688	1.94	13.0	1.62	2-11	MKM 4534	M12 x 100	228	12.0
		1360-32-32M12 <sup>+</sup>							M12x1.75			---	---		

MATERIAL:  
Low Carbon Steel<sup>®</sup>

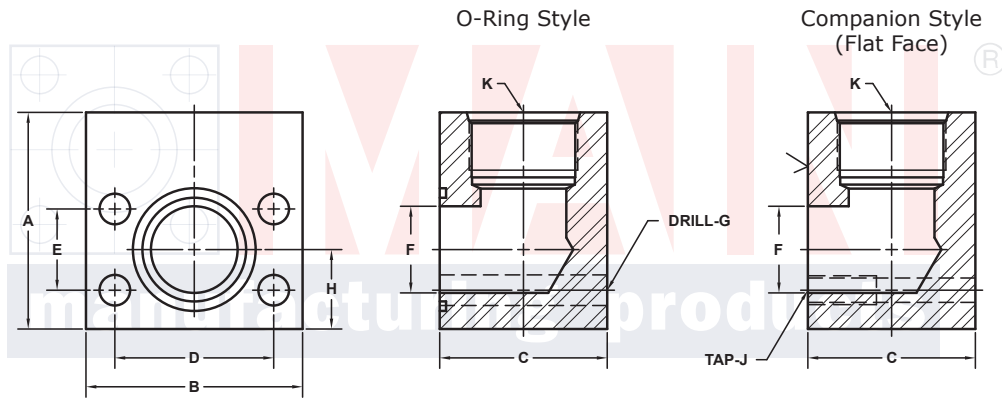

Model 1359 / 1361

Model 1360 / 1362

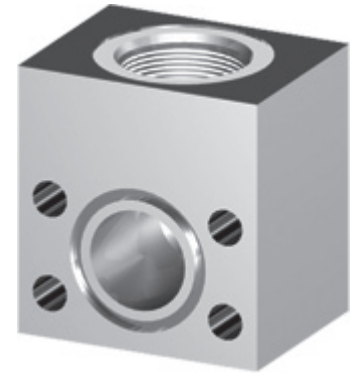

3181 TRI-PARK DR. GRAND BLANC, MI 48439 800-521-7918 810-953-1380 FAX 810-953-1385 INFO@MAINMFG.COM

## SAE J518 62 SERIES / ISO6162-2 PATTERN

FLANGE SIZE	PORT SIZE	PART NUMBER	A	B	C	D	E	F	Gmm Jmm	H	K	MOUNTING KIT <sup>①</sup>			WT
												PART NO.	SCREW SIZE	O-RING	
1/2	-8	1361-08-08M8	2.00	2.22	1.46	1.594	.718	.50	8.5	.88	1/2-14	MKM 541	M8 x 50	210	1.6
		1362-08-08M8							M8x1.25			---	---		
3/4	-8	1361-12-08M10	2.50	2.81	1.70	2.000	.937	.50	10.5	1.00	1/2-14	MKM 542	M10 x 60	214	3.0
		1362-12-08M10							M10x1.5			---	---		
3/4	-12	1361-12-12M10	2.50	2.81	1.70	2.000	.937	.75	10.5	1.00	3/4-14	MKM 542	M10 x 60	214	2.8
		1362-12-12M10							M10x1.5			---	---		
1	-12	1361-16-12M12	3.00	3.19	1.96	2.250	1.093	.75	12.5	1.12	3/4-14	MKM 551	M12 x 70	219	4.5
		1362-16-12M12							M12x1.75			---	---		
1	-16	1361-16-16M12	3.00	3.19	1.96	2.250	1.093	1.00	12.5	1.12	1-11	MKM 551	M12 x 70	219	4.3
		1362-16-16M12							M12x1.75			---	---		
1 1/4	-20	1361-20-20M12 <sup>+</sup>	4.00	3.75	2.44	2.625	1.250	1.25	13.0	1.38	1 1/4-11	MKM 578	M12 x 80	222	8.3
		1362-20-20M12 <sup>+</sup>							M12x1.75			---	---		
1 1/2	-24	1361-24-24M16	4.00	4.50	2.96	3.125	1.437	1.50	17.0	1.62	1 1/2-11	MKM 553	M16 x 100	225	12.0
		1362-24-24M16							M16x2			---	---		
2	-32	1361-32-32M20	5.00	5.25	3.46	3.812	1.750	1.94	21.0	2.00	2-11	MKM 554	M20 x 120	228	19.7
		1362-32-32M20							M20x2.5			---	---		

① Order Separately

⑤ May Contain Lead

**NOTE:** The Pressure Rating of the Assembly Should NOT Exceed the Lower of the Flange Pad or the Fitting. Check the Fitting Manufacturer for Details.  
NOTE: DIMENSIONS ARE IN INCHES UNLESS OTHERWISE NOTED. + Also Available for M12 Bolts † Also Available for M14 Bolts

© Copyright MAIN Mfg. 2017