

BUTT WELD IN-LINE FLANGES

For Schedule XXS Pipe ®

3000 SERIES SQUARE BOLT PATTERN

FLANGE SIZE	PIPE SIZE	PART NUMBER	A	B	C	D	E	F	G		H	K	MOUNTING KIT®			WT
									J				PART NO.	SCREW SIZE	O-RING	
3/4	3/4	1407-12-12	2.25	1.12	1.25	.719	1.438	.44	.41	.38	1.12	MK 528	3/8-16 x 1 3/4	216	1.3	
		3/8-16							-----							---
1	1	1407-16-16	3.00	1.50	1.50	1.000	2.000	.60	.53	.50	1.38	MK 529	1/2-13 x 1 3/4	222	2.6	
		1/2-13							-----							---
1 1/4	1 1/4	1407-20-20	3.00	1.50	1.50	1.000	2.000	.89	.53	.50	1.75	MK 529	1/2-13 x 1 3/4	222	2.6	
		1/2-13							-----							---
1 1/2	1 1/2	1407-24-24	4.00	2.00	1.50	1.375	2.750	1.10	.66	.50	2.00	MK 581	5/8-11 x 2	228	4.5	
		5/8-11							-----							---
2	2	1407-32-32	4.00	2.00	1.50	1.375	2.750	1.50	.66	.50	2.50	MK 581	5/8-11 x 2	228	4.3	
		5/8-11							-----							---
2 1/2	2 1/2	1407-40-40	5.50	2.75	2.00	1.875	3.750	1.77	.94	.75	3.00	MK 1519	7/8-9 x 2 1/2	236	9.9	
		7/8-9							-----							---
3	3	1407-48-48	5.50	2.75	2.00	1.875	3.750	2.30	.94	.75	3.50	MK 1519	7/8-9 x 2 1/2	236	9.6	
		7/8-9							-----							---
3 1/2	3 1/2	1407-56-56	6.00	3.00	2.00	2.125	4.250	2.73	.94	.75	4.00	MK 1577	7/8-9 x 2 1/2	240	11.2	
		7/8-9							-----							---
4	4	1407-64-64	7.00	3.50	2.50	2.500	5.000	3.15	1.06	1.00	4.50	MK 1578	1-8 x 3	347	18.0	
		1-8							-----							---
5	5	1407-80-80	8.00	4.00	3.00	3.000	6.000	4.06	1.06	1.00	5.62	MK 1579	1-8 x 3 1/2	355	30.0	
		1-8							-----							---
6	6	1407-96-96	10.00	5.00	3.00	3.500	7.000	4.88	1.31	1.00	6.75	MK 5533	1 1/4-7 x 4	362	47.0	
		1 1/4-7							-----							---

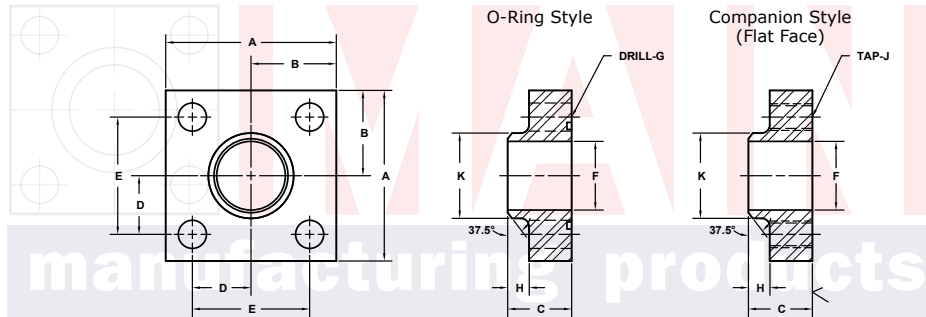

MATERIAL: **Low Carbon Steel** Model 1407 / 1409 Model 1408 / 1410
 3181 TRI-PARK DR. GRAND BLANC, MI 48439 800-521-7918 810-953-1380 FAX 810-953-1385 INFO@MAINMFG.COM

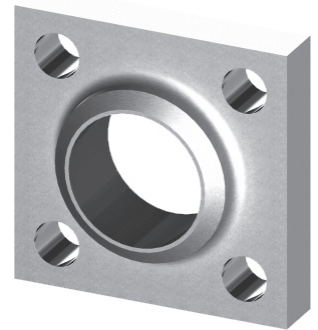

6000 SERIES SQUARE BOLT PATTERN

FLANGE SIZE	PIPE SIZE	PART NUMBER	A	B	C	D	E	F	G		H	K	MOUNTING KIT®			WT
									J				PART NO.	SCREW SIZE	O-RING	
1/2	1/2	1409-08-08	2.25	1.12	1.50	.719	1.438	.25	.41	.50	.88	MK 2501	3/8-16 x 1 3/4	210	1.5	
		3/8-16							-----							---
3/4	3/4	1409-12-12	2.50	1.25	1.50	.875	1.750	.44	.41	.50	1.12	MK 2502	3/8-16 x 1 3/4	214	1.9	
		3/8-16							-----							---
1	1	1409-16-16	3.00	1.50	1.50	1.000	2.000	.60	.53	.50	1.38	MK 2503	1/2-13 x 2	219	2.5	
		1/2-13							-----							---
1 1/4	1 1/4	1409-20-20	4.00	2.00	2.00	1.375	2.750	.89	.66	.75	1.75	MK 2504	5/8-11 x 2 1/2	222	5.5	
		5/8-11							-----							---
1 1/2	1 1/2	1409-24-24	4.00	2.00	2.25	1.375	2.750	1.10	.66	.75	2.00	MK 2505	5/8-11 x 2 3/4	225	6.5	
		5/8-11							-----							---
2	2	1409-32-32	5.00	2.50	2.50	1.750	3.500	1.50	.78	.75	2.50	MK 2506	3/4-10 x 3 1/2	228	11.7	
		3/4-10							-----							---
2 1/2	2 1/2	1409-40-40	5.50	2.75	2.50	1.875	3.750	1.77	.94	.75	3.00	MK 2507	7/8-9 x 3 1/2	232	13.8	
		7/8-9							-----							---
3	3	1409-48-48	7.00	3.50	3.00	2.375	4.750	2.30	1.06	1.00	3.50	MK 2508	1-8 x 4	236	25.2	
		1-8							-----							---
3 1/2	3 1/2	1409-56-56	8.00	4.00	3.50	2.750	5.500	2.73	1.31	1.00	4.00	MK 2509	1 1/4-7 x 5	342	39.5	
		1 1/4-7							-----							---
4	4	1409-64-64	8.50	4.25	3.50	3.000	6.000	3.15	1.31	1.00	4.50	MK 2510	1 1/4-7 x 5	346	44.2	
		1 1/4-7							-----							---
5	5	1409-80-80	10.00	5.00	4.00	3.625	7.250	4.06	1.56	1.00	5.62	MK 2511	1 1/2-6 x 6	353	70.5	
		1 1/2-6							-----							---

① Order Separately

® Schedules 40, 80 and 160 also Stocked. Other Pipe and Tube Sizes are Available