

BUTT WELD ELBOW FLANGES

For Schedule 160 Pipe ⑥

3000 SERIES SQUARE BOLT PATTERN

FLANGE SIZE	PIPE SIZE	PART NUMBER	A	B	C	D	E	F	G	H	K	MOUNTING KIT®			WT
									J			PART NO.	SCREW SIZE	O-RING	
1/2	1/2	1427-08-08	2.75	2.25	1.50	.719	1.438	.47	.41	.38	.88	MK 532	3/8-16 x 2 1/4	216	2.0
		1428-08-08							3/8-16						
3/4	3/4	1427-12-12	2.75	2.25	1.50	.719	1.438	.61	.41	.38	1.12	MK 532	3/8-16 x 2 1/4	216	1.9
		1428-12-12							3/8-16						
1	1	1427-16-16	3.50	3.00	2.00	1.000	2.000	.81	.53	.38	1.38	MK 533	1/2-13 x 2 3/4	222	4.4
		1428-16-16							1/2-13						
1 1/4	1 1/4	1427-20-20	3.50	3.00	2.25	1.000	2.000	1.16	.53	.38	1.75	MK 534	1/2-13 x 3	222	4.7
		1428-20-20							1/2-13						
1 1/2	1 1/2	1427-24-24	4.62	4.00	3.00	1.375	2.750	1.34	.66	.50	2.00	MK 535	5/8-11 x 4	228	11.5
		1428-24-24							5/8-11						
2	2	1427-32-32	4.62	4.00	3.50	1.375	2.750	1.69	.66	.50	2.50	MK 1598	5/8-11 x 4 1/2	228	12.4
		1428-32-32							5/8-11						
2 1/2	2 1/2	1427-40-40	6.25	5.50	4.00	1.875	3.750	2.12	.94	.75	3.00	MK 536	7/8-9 x 5 1/2	236	26.3
		1428-40-40							7/8-9						
3	3	1427-48-48	6.25	5.50	4.50	1.875	3.750	2.62	.94	.75	3.50	MK 537	7/8-9 x 6	236	28.6
		1428-48-48							7/8-9						
3 1/2	3 1/2	1427-56-56	7.00	6.00	5.50	2.125	4.250	3.00	.94	1.00	4.00	MK 3528	7/8-9 x 7	240	42.3
		1428-56-56							7/8-9						
4	4	1427-64-64	8.00	7.00	6.00	2.500	5.000	3.44	1.06	1.00	4.50	MK 2573	1-8 x 7 1/2	347	61.8
		1428-64-64							1-8						
5	5	1427-80-80	9.00	8.00	7.00	3.000	6.000	4.31	1.06	1.00	5.62	MK 3522	1-8 x 8 1/2	355	89.6
		1428-80-80							1-8						

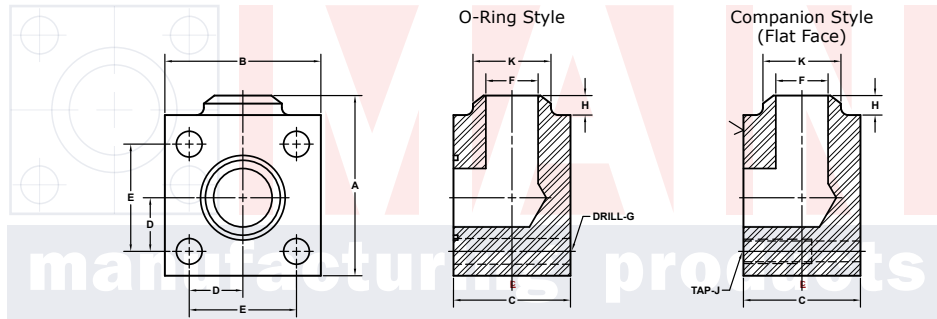

MATERIAL: **Low Carbon Steel**

Model 1427 / 1429

Model 1428 / 1430

3181 TRI-PARK DR. GRAND BLANC, MI 48439 800-521-7918 810-953-1380 810-953-1385 FAX 810-953-1385 INFO@MAINMFG.COM

6000 SERIES SQUARE BOLT PATTERN

FLANGE SIZE	PIPE SIZE	PART NUMBER	A	B	C	D	E	F	G	H	K	MOUNTING KIT®			WT
									J			PART NO.	SCREW SIZE	O-RING	
1/2	1/2	1429-08-08	2.75	2.25	1.50	.719	1.438	.47	.41	.38	.88	MK 5515	3/8-16 x 2 1/4	210	2.0
		1430-08-08							3/8-16						
3/4	3/4	1429-12-12	3.00	2.50	1.75	.875	1.750	.61	.41	.38	1.12	MK 542	3/8-16 x 2 1/2	214	2.9
		1430-12-12							3/8-16						
1	1	1429-16-16	3.50	3.00	2.25	1.000	2.000	.81	.53	.38	1.38	MK 5516	1/2-13 x 2 3/4	219	5.1
		1430-16-16							1/2-13						
1 1/4	1 1/4	1429-20-20	4.62	4.00	3.00	1.375	2.750	1.16	.66	.38	1.75	MK 5517	5/8-11 x 4	222	12.3
		1430-20-20							5/8-11						
1 1/2	1 1/4	1429-24-20	4.62	4.00	3.00	1.375	2.750	1.16	.66	.50	1.75	MK 553	5/8-11 x 4	225	11.8
		1430-24-20							5/8-11						
1 1/2	1 1/2	1429-24-24	4.62	4.00	3.00	1.375	2.750	1.34	.66	.50	2.00	MK 553	5/8-11 x 4	225	11.6
		1430-24-24							5/8-11						
2	1 1/2	1429-32-24	5.50	5.00	4.00	1.750	3.500	1.34	.78	.50	2.00	MK 4580	3/4-10 x 5 1/2	228	24.1
		1430-32-24							3/4-10						
2	2	1429-32-32	5.50	5.00	4.00	1.750	3.500	1.69	.78	.50	2.50	MK 4580	3/4-10 x 5 1/2	228	23.6
		1430-32-32							3/4-10						
2 1/2	2	1429-40-32	6.25	5.50	4.50	1.875	3.750	1.69	.94	.75	2.50	MK 2557	7/8-9 x 6	232	31.4
		1430-40-32							7/8-9						
2 1/2	2 1/2	1429-40-40	6.25	5.50	4.50	1.875	3.750	2.12	.94	.75	3.00	MK 2557	7/8-9 x 6	232	30.6
		1430-40-40							7/8-9						
3	3	1429-48-48	7.50	7.00	5.00	2.375	4.750	2.62	1.06	.75	3.50	MK 5518	1-8 x 7	236	57.0
		1430-48-48							1-8						

① Order Separately

⑥ Schedules 40, 80 and XXS also Stocked. Other Pipe and Tube Sizes are Available