

SAE J1926 THREADED IN-LINE FLANGES

ISO 6164 x SAE ORB										250 BAR SERIES ^②				
FLANGE SIZE	PORT SIZE	PART NUMBER	A	B	C	Dmm	E	F	Gmm Jmm	K	MOUNTING KIT ^①			WT
											PART NO.	BOLT SIZE	O-RING	
10	-6	1667-06-06M	1.50	.75	1.25	35	.974	.47	6.5	9/16-18	MKM 5568	M6 x 35	115	.7
		1668-06-06M							M6x1					
13	-8	1667-08-08M	1.75	.88	1.25	42	1.170	.50	9.0	3/4-16	MKM 512	M8 x 35	210	.8
		1668-08-08M							M8x1.25					
19	-12	1667-12-12M	2.00	1.00	1.50	50	1.392	.75	9.0	1 1/16-12	MKM 5559	M8 x 35	214	1.2
		1668-12-12M							M8x1.25					
25	-16	1667-16-16M	2.50	1.25	1.50	62	1.726	1.00	11.0	1 5/16-12	MKM 503	M10 x 40	219	1.8
		1668-16-16M							M10x1.5					
32	-20	1667-20-20M	3.00	1.50	1.50	73	2.032	1.25	13.5	1 5/8-12	MKM 1527	M12 x 40	222	2.5
		1668-20-20M							M12x1.75					
38	-24	1667-24-24M	3.50	1.75	1.75	85	2.366	1.50	17.5	1 7/8-12	MKM 1544	M16 x 45	225	3.8
		1668-24-24M							M16x2					
51	-32	1667-32-32M	4.00	2.00	1.75	98	2.728	1.94	17.5	2 1/2-12	MKM 1524	M16 x 45	228	4.8
		1668-32-32M							M16x2					
56	-32	1667-40-32M	4.75	2.38	2.00	118	3.285	2.32	22.0	2 1/2-12	MKM 5570	M20 x 60	232	8.5
		1668-40-32M							M20x2.5					
63	-32	1667-48-32M	5.50	2.75	2.25	145	4.037	2.32	22.0	2 1/2-12	MKM 5571	M20 x 65	237	14.7
		1668-48-32M							M20x2.5					

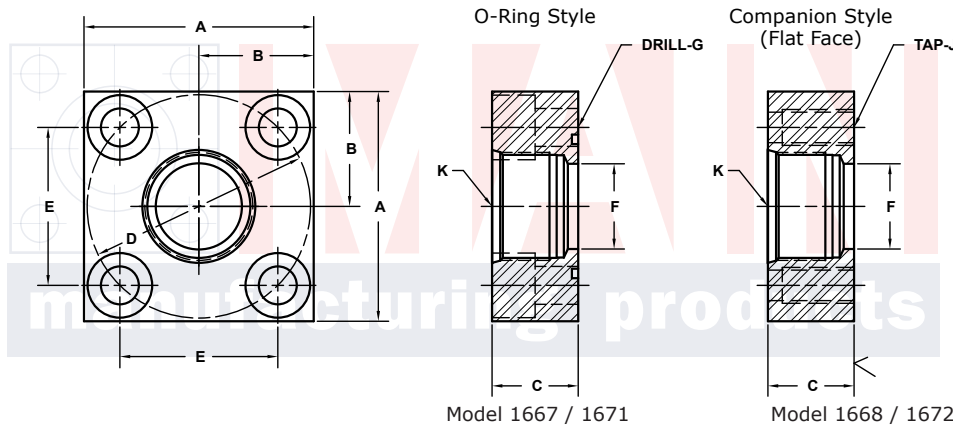

MATERIAL:
Low Carbon Steel[®]

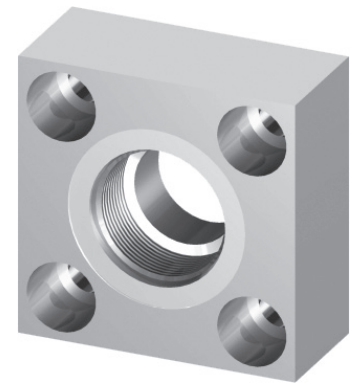

3181 TRI-PARK DR. GRAND BLANC, MI 48439 800-521-7918 810-953-1380 FAX 810-953-1385 INFO@MAINMFG.COM

ISO 6164 x ISO 6149										250 BAR SERIES ^②				
FLANGE SIZE	PORT SIZE	PART NUMBER	A	B	C	Dmm	E	F	Gmm Jmm	Kmm	MOUNTING KIT ^①			WT
											PART NO.	BOLT SIZE	O-RING	
10	-6	1671-06-06M	1.50	.75	1.25	35	.974	.47	6.5	M16 x 1.5	MKM 5568	M6 x 35	115	.7
		1672-06-06M							M6x1					
13	-8	1671-08-08M	1.75	.88	1.25	42	1.170	.50	9.0	M18 x 1.5	MKM 512	M8 x 35	210	.8
		1672-08-08M							M8x1.25					
19	-12	1671-12-12M	2.00	1.00	1.50	50	1.392	.75	9.0	M27 x 2	MKM 5559	M8 x 35	214	1.2
		1672-12-12M							M8x1.25					
25	-16	1671-16-16M	2.50	1.25	1.50	62	1.726	1.00	11.0	M33 x 2	MKM 503	M10 x 40	219	1.8
		1672-16-16M							M10x1.5					
32	-20	1671-20-20M	3.00	1.50	1.50	73	2.032	1.25	13.5	M42 x 2	MKM 1527	M12 x 40	222	2.5
		1672-20-20M							M12x1.75					
38	-24	1671-24-24M	3.50	1.75	1.75	85	2.366	1.50	17.5	M48 x 2	MKM 1544	M16 x 45	225	3.8
		1672-24-24M							M16x2					
51	-32	1671-32-32M	4.00	2.00	1.75	98	2.728	1.94	17.5	M60 x 2	MKM 1524	M16 x 45	228	4.8
		1672-32-32M							M16x2					
56	-32	1671-40-32M	4.75	2.38	2.00	118	3.285	2.12	22.0	M60 x 2	MKM 5570	M20 x 60	232	8.5
		1672-40-32M							M20x2.5					
63	-32	1671-48-32M	5.50	2.75	2.25	145	4.037	2.12	22.0	M60 x 2	MKM 5571	M20 x 65	237	14.7
		1672-48-32M							M20x2.5					

① Order Separately ② 400BAR Series also available, contact engineering for information

⑤ May Contain Lead

NOTE: The pressure rating of the assembly should not exceed the lower of the flange pad or the fitting. Check the fitting manufacturer for details.

NOTE: DIMENSIONS ARE IN INCHES UNLESS OTHERWISE NOTED.

© Copyright MAIN Mfg. 2017