

'MAIN' COUPLINGS

NPTF x NPTF							
SIZE (C)	SIZE (D)	PART NUMBER	A	B	C NPTF	D NPTF	WT
1/4	1/4	1265-04-04	1.50	1.00	1/4	1/4	.3
3/8	3/8	1265-06-06	1.75	1.25	3/8	3/8	.5
1/2	1/2	1265-08-08	2.00	1.50	1/2	1/2	.4
3/4	3/4	1265-12-12	2.25	1.75	3/4	3/4	1.1
1	1	1265-16-16	2.50	2.25	1	1	2.1
1 1/4	1 1/4	1265-20-20	2.50	2.50	1 1/4	1 1/4	2.2
1 1/2	1 1/2	1265-24-24	2.50	3.00	1 1/2	1 1/2	3.3
2	2	1265-32-32	3.00	3.62	2	2	5.4

SAE ORB x SAE ORB							
SIZE (C)	SIZE (D)	PART NUMBER	A	B	C ORB	D ORB	WT
-4	-4	1266-04-04	1.25	1.00	7/16-20	7/16-20	.3
-6	-6	1266-06-06	1.38	1.12	9/16-18	9/16-18	.4
-8	-8	1266-08-08	1.50	1.25	3/4-16	3/4-16	.5
-10	-10	1266-10-10	1.75	1.50	7/8-14	7/8-14	.7
-12	-8	1266-12-08	2.25	1.75	1 1/16-12	3/4-16	1.3
-12	-12	1266-12-12	2.00	1.75	1 1/16-12	1 1/16-12	1.0
-14	-14	1266-14-14	2.00	1.88	1 3/16-12	1 3/16-12	1.1
-16	-16	1266-16-16	2.00	2.00	1 5/16-12	1 5/16-12	1.2
-20	-20	1266-20-20	2.00	2.38	1 5/8-12	1 5/8-12	1.5
-24	-24	1266-24-24	2.00	2.62	1 7/8-12	1 7/8-12	1.7
-32	-32	1266-32-32	2.00	3.50	2 1/2-12	2 1/2-12	2.9

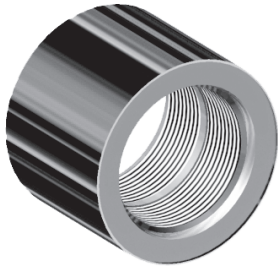

MATERIAL:
Low Carbon Steel[®]

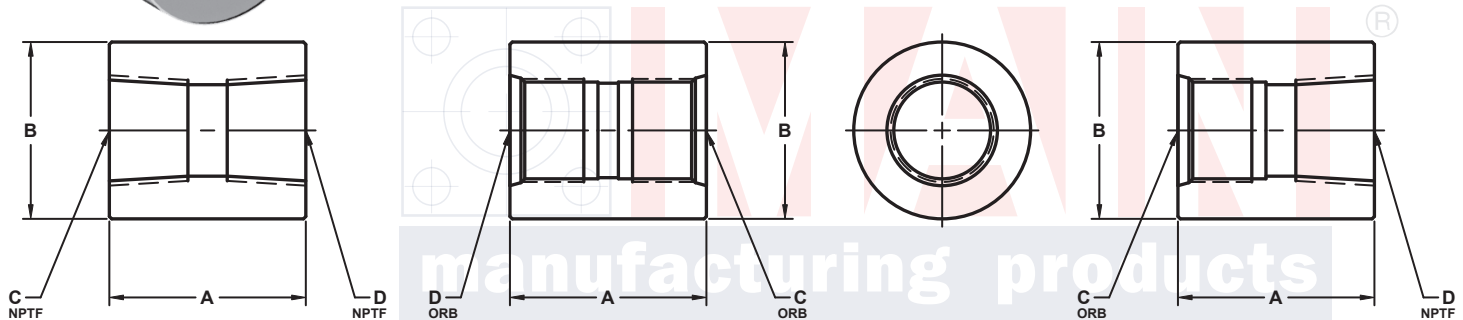

Model 1265

Model 1266

Model 1267

3181 TRI-PARK DR. GRAND BLANC, MI 48439 800-521-7918 810-953-1380 FAX 810-953-1385 INFO@MAINMFG.COM

SAE ORB x NPTF							
SIZE (C)	SIZE (D)	PART NUMBER	A	B	C ORB	D NPTF	WT
-4	1/4	1267-04-04	1.25	1.00	7/16-20	1/4	.3
-8	1/2	1267-08-08	2.00	1.50	3/4-16	1/2	.9
-12	1/2	1267-12-08	2.25	1.75	1 1/16-12	1/2	1.3
-12	3/4	1267-12-12	2.25	1.75	1 1/16-12	3/4	1.2
-12	1	1267-12-16	2.50	2.25	1 1/16-12	1	2.2
-16	1	1267-16-16	2.50	2.25	1 5/16-12	1	2.1
-20	1 1/4	1267-20-20	2.50	2.50	1 5/8-12	1 1/4	2.2
-24	1 1/2	1267-24-24	2.50	3.00	1 7/8-12	1 1/2	3.3
-32	2	1267-32-32	3.00	3.62	2 1/2-12	2	5.3

® May Contain Lead

NOTE: The pressure rating of the assembly should not exceed the lower of the flange pad or the fitting. Check the fitting manufacturer for details.